



**PULVIS MINI SPRAY
GB210A
PULVIS MINI BED
GB210B**

Instruction Manual

- Second Edition -

● Thank you for purchasing " PULVIS GB Series" of Yamato Scientific Co., Ltd.

● To use this unit properly, read this "Instruction Manual" thoroughly before using this unit.

Keep this instruction manual around this unit for referring at anytime.



: WARNING!:

Carefully read and thoroughly understand the important warning items described in this manual before using this unit.

Yamato Scientific Co. LTD.,

This paper has been printed on recycled pap

1. Safety precautions	1
Explanation of pictograms	1
List of symbols	2
Warning · Cautions	3
2. Before using this unit.	5
Precautions when installing the unit	5
Service receptacle capacity	8
Temperature output terminal.	8
3. Names of parts and their function.	9
Specifications of GB 210B (GB210 + GF200)	9
Specifications of GB 210A (GB210 + GF300)	10
Operation panel	11
4. Operating procedures	12
Preparations	12
Operating method	18
Operating method of GB210B.	19
Operating method of GB210B.	25
Operating method of GB210A/GB210B.	28
5. Handling Precautions	29
Drying Method under Appropriate Condition	30
Drying Method under Appropriate Condition	31
6. Maintenance Method.	33
Daily Inspection and Maintenance.	33
7. Long storage and disposal	35
When not using this unit for long term / When disposing	35
Matters to consider when disposing of the unit	35
8. When a trouble occurs	36
Safety unit and error indications	36
Confirmation of GB210A manual and language selection display	37
Confirmation of GB210B manual and language selection display	39
Trouble Shooting	41
9. After Service and Warranty	43
When requesting a repair	43
10. Specification	44
11. Wiring Diagram	47
12. System Chart	48
System Chart of GB210B	48
System Chart of GB210A	49
13. Principle of Operation	50
14. Replacement parts table.	51
15. List of Dangerous Substances.	55

1. Safety precautions

Explanation of pictograms

About pictograms

A variety of pictograms are indicated in this operating instruction and on products for safe operation. Possible results from improper operation ignoring them are as follows.

Be sure to fully understand the descriptions below before proceeding to the text.

 **Warning** Indicates a situation which may result in death or serious injury (Note 1.)

 **Caution** Indicates a situation which may result in minor injury (Note 2) and property damages (Note 3.)

(Note 1) Serious injury means a wound, an electrical shock, a bone fracture or intoxication that may leave after effects or require hospitalization or outpatient visits for a long time.

(Note 2) Minor injury means a wound or an electrical shock that does not require hospitalization or outpatient visits for a long time.

(Note 3) Property damage means damage to facilities, devices and buildings or other properties.

Meanings of pictograms



This pictogram indicates a matter that encourages the user to adhere to warning ("caution" included).
Specific description of warning is indicated near this pictogram.



This pictogram indicates prohibitions
Specific prohibition is indicated near this pictogram.



This pictogram indicates matters that the user must perform
Specific instruction is indicated near this pictogram.

1. Safety precautions

List of symbols

Warning



General warnings



Danger!: High voltage



Danger!: High temperature



Danger!: Moving part



Danger!: Hazard of explosion

Caution



General cautions



Electrical shock!



Burning!



Caution for no liquid heating!



Caution for water leak!



For water only



Poisonous material

Prohibitions



General bans



Fire ban



Do not disassemble



Do not touch

Compulsions



General compulsions



Connect ground wire



Install levelly



Pull out the power plug



Regular inspection

1. Safety precautions

Warning · Cautions

Warning

Do not use this unit in an area where there is flammable or explosive gas

Never use this unit in an area where there is flammable or explosive gas. This unit is not explosion-proof. An arc may be generated when the power switch is turned on or off, and fire/explosion may result. (Refer to page 42 "15. List of Dangerous Substances".)

Always ground this unit

Always ground this unit on the power equipment side in order to avoid electrical shock due to a power surge.

Apply the source of rated power or more

Be sure to apply the source of rated power or more. Applying non-rated voltage or non-rated power supply may cause the fire or electric shock.

Prohibition of use for error

If a smoke or abnormal smell may be occurred, turn off the power switch of the main unit immediately, and turn off the original power source, and finally contact to either the dealer you purchased this unit or our sales office. Leaving the failure may cause the fire or electric shock. Since the repairing of this unit is dangerous for non-specified service person, never repair the unit by the customer himself.

Do not use the power cord if it is bundled or tangled

Do not use the power cord if it is bundled or tangled. If it is used in this manner, it can overheat and fire may be caused.

Do not damage power cord

Do not damage power cord by bending, pulling, or twisting forcedly. It may cause the fire or electric shock. Besides, operating the unit with the something put on the cord may cause overheat, and result in fire.

Never use an explosive or a flammable material with this unit.

Never use an explosive material, a flammable material or a material containing them. An explosion or an electrical shock may result. **GB210A supports organic solvents by connecting it to the optional GAS410. Carefully read the operation manual of GAS410 and take special care for handling of organic solvents.**

See section "15. List of Dangerous Substances" on page 42.

Never try to touch a hot part.

Some parts of the unit are hot during and immediately after operation. Take special care for possible burning.

Never try to disassemble or alter the unit.

Never try to disassemble or alter the unit. A malfunction, a fire or an electrical shock may result.

1. Safety precautions

Warning · Cautions

Caution

During a thunder storm

During a thunderstorm, turn off the power key immediately, then turn off the circuit breaker and the main power. If this procedure is not followed, fire or electrical shock may be caused.

• **If the electric failure shall be occurred,**

When power is shut off during operation (while the blower is operating or liquid is being sent) due to turning of the ELB to "OFF" or a power failure, all operation modes will reset to the initial states after recovery. When the temperature inside the chamber has been high, keep operating the blower until it cools down to 45°C or below after recovery from a power failure.

• **Do not perform unattended operation during activating the unit**

Do not perform unattended operation during activating the unit. Since the unit is in idling status and the nozzle is blocked of after the operation using sample, the temperature around outlet is increased and the remaining sample is flown from the sample tube disconnected from the unit, and this failure may cause the indeterminism accident.

About countermeasures against static electricity



The cyclone may charge with static electricity depending on the specific specimen used, or operating environment or conditions. Implement countermeasures against static electricity such as attaching included earth clips at three positions on the clamp at the connection of the cyclone or attaching an antistatic brush (optional) to the body of the cyclone.

2. Before using this unit

Precautions when installing the unit

Warning

1. Always ground this unit

- Be sure to connect the earth wire (the green cable of power cord) to the grounding conductor or ground terminal to prevent accidents caused by electric leakage.
- This unit requires a single phase 200V power supply (also supports AC220V or AC240V by selecting either of it) (See page 12 (1)) Ask the nearest electrical contractor for the power including the connecting work. The setting (connecting) work is performed following the related electrical equipment technical standard published by the corresponding country to be used this unit.
- Do not connect the earth wire to gas or water pipes. If not, fire disaster may be caused.
- Do not connect the earth wire to the ground for telephone wire or lightning conductor. If not, fire disaster or electric shock may be caused.

- The power plug is not attached as standard component. Connect the earth correctly adjusting the type of the power equipment of the user.

Rounded terminal for M5

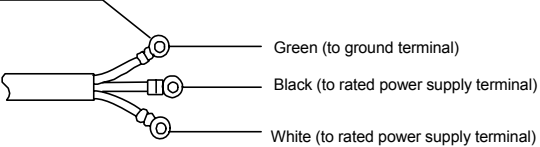

2. Pay attention to the color of each core wire when connecting the power cord

 <p>Be sure to check that the breaker on the power source equipment side is turned "OFF" when connecting power cord without fail. Note that the ADL311 does not attach the power plug as standard component. Select the appropriate power plug and terminal matching to the power capacity of the power source equipment to be connected, and connect them.</p>	Core Wire Color	In-house Wiring
	Black	Voltage Side
	White	Voltage Side
	Green	Ground Side

3. Choose a proper place for installation



Do not install this unit in a place where:

- Rough or dirty surface.
- Flammable gas or corrosive gas is generated.
- Ambient temperature bellow 5°C or above 30°C.
- Ambient temperature fluctuates violently.
- There is direct sunlight.
- There is excessive humidity and dust.
- There is a constant vibration.
- Place where the water is easy-to-be splashed.



Install this unit on a stable place with the space as shown below.

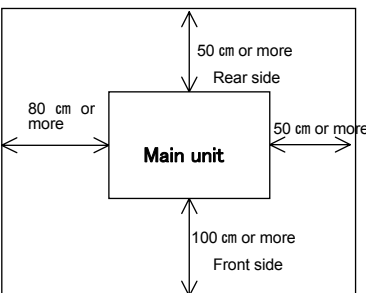

Before using this unit

Precautions when installing the unit



Warning

4. Do not use this unit in an area where there is flammable or explosive gas

- ⊘ Never use this unit in an area where there is flammable or explosive gas. This unit is not explosion-proof. An arc may be generated when the power switch is turned ON or OFF, and fire/explosion may result.



Refer to page 56 "15. List of Dangerous Substances

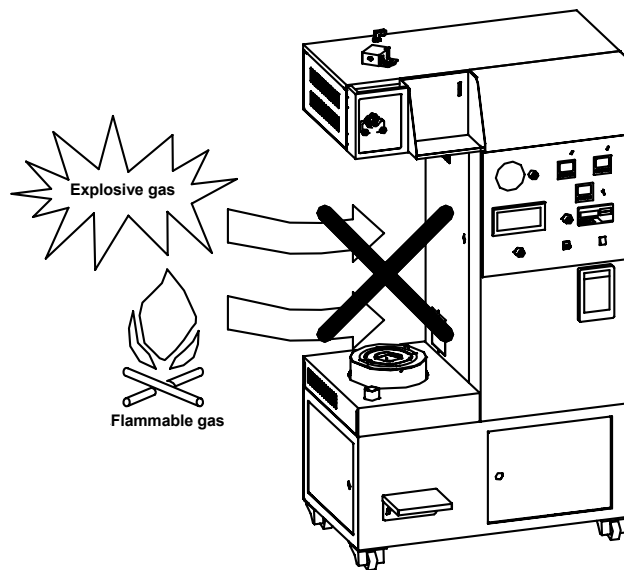

5. Do not use explosive or flammable substances

- ⊘ Never use explosive substances, flammable substances and substances that include explosive or flammable ingredients in this unit. Explosion or fire may occur. Refer to page 56 "15. List of Dangerous Substances

GB210A supports organic solvents by connecting it to the optional GAS410. Carefully read the operation manual of GAS410 and take special care for handling of organic solvents.

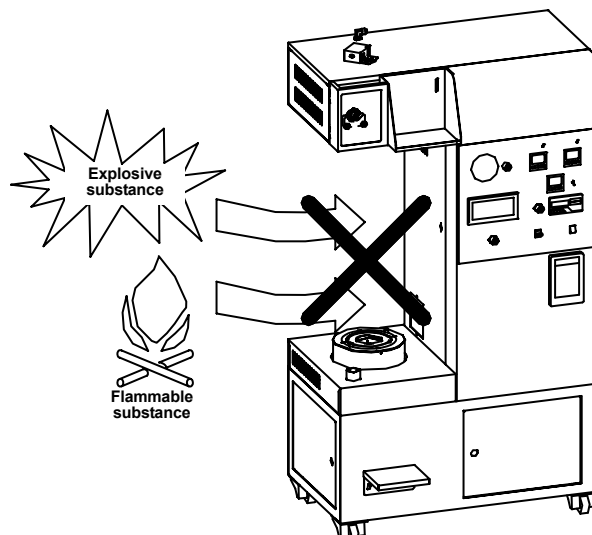

2. Before using this unit

Precautions when installing the unit



Warning

6. Do not modify



Modification of this unit is strictly prohibited. This could cause a failure.

Modification

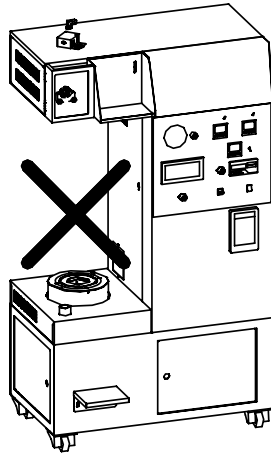

7. Do not topple or tilt this unit



Set this unit to the flattest place. Setting this unit on rough or slope place could cause the vibration or noise, or cause the unrespectable trouble or malfunction.

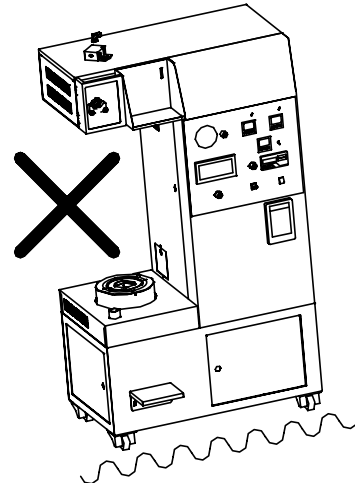

8. Be sure to connect the power supply to a facility that comply with the electric capacitance.



Electric capacity: AC200V Single phase 16A (AC220V Single phase 17A, AC240V Single phase 18A)

The specification has set to 200V at the time of factory shipping. If you want to switch to AC220V or AC240V power supply, first change the terminal position in the unit before connecting a power supply. (See " Before Using this unit " on P.12)

There could be the case that the unit does not run even after turning ON the power. Inspect whether the voltage of the main power is lowered than the specified value, or whether other device(s) uses the same power line of this unit. If the phenomena might be found, change the power line of this unit to the other power line.

For connecting of the device to the power source, ask the dealer that you purchased this unit from or an electrical contractor for safe.

9. Handling of power code



Do not entangle the power cord. This will cause overheating and possibly a fire.

Do not bend or twist the power cord, or apply excessive tension to it. This may cause a fire and electrical shock.

Do not lay the power cord under a desk or chair, and do not allow it to be pinched in order to prevent it from being damaged and to avoid a fire or electrical shock.

Keep the power cord away from any heating equipment such as a room heater. The cord's insulation may melt and cause a fire or electrical shock.

If the power cord becomes damaged (wiring exposed, breakage, etc.), immediately turn off the power at the rear of this unit and shut off the main supply power. Then contact your nearest dealer for replacement of the power cord. Leaving it may cause a fire or electrical shock.



Connect the power plug to the receptacle which is supplied appropriate power and voltage.

2. Before using this unit

Service receptacle capacity

Service receptacle capacity



Apply the 100V 2A or less service receptacle for this unit.

Connecting the service receptacle with its capacity over 2A blowouts the fuse, and the power source to the service receptacle is shut down. For resetting this damage, replace the fuse in the fuse holder on the right side of the back of the unit.

Applicable models

Mag mixer: MA series, M-21, MD series, MC800, MF800

Use a separate power supply for a unit with a heater and its total current exceeds 2A

Temperature output terminal

Temperature output signals at the outlet, the inlet during spray drying (GB210A), and the inlet during granulation (GB210B) are of 4-20mA for the measured temperature range of 40-240°C.

[Current output of 4-20mA : Measured temperature of 40-240°C]

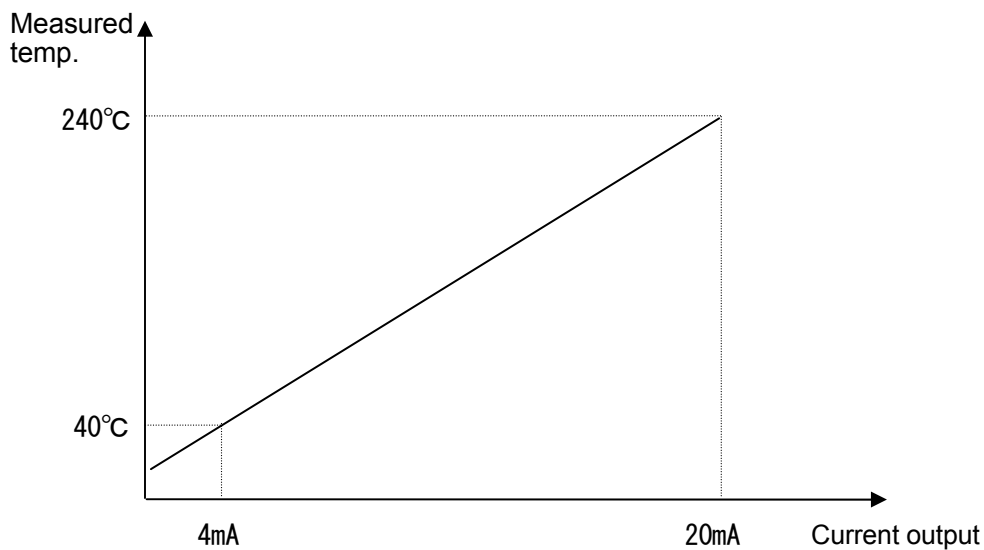

Conversion formula: Current output I (mA) = 0.08 x (measured temperature T(°C)) + 10

Measured temperature T(°C) = 12.5 x current output I (mA) - 10

When you connecting to the voltage input of the recorder, connect a fixed resistor (shunt resistor) of 600Ω or lower.

⊗	
⊗	+ Inlet temp
⊗	- (4~20mA : 40~240°C)
⊗	+ Outlet temp
⊗	- (4~20mA : 40~240°C)
⊗	+ Inlet temp (GRANULE)
⊗	- (4~20mA : 40~240°C)
⊗	

3.Names of parts and their function

Specifications of GB 210B (GB210 + GF200)

Front side

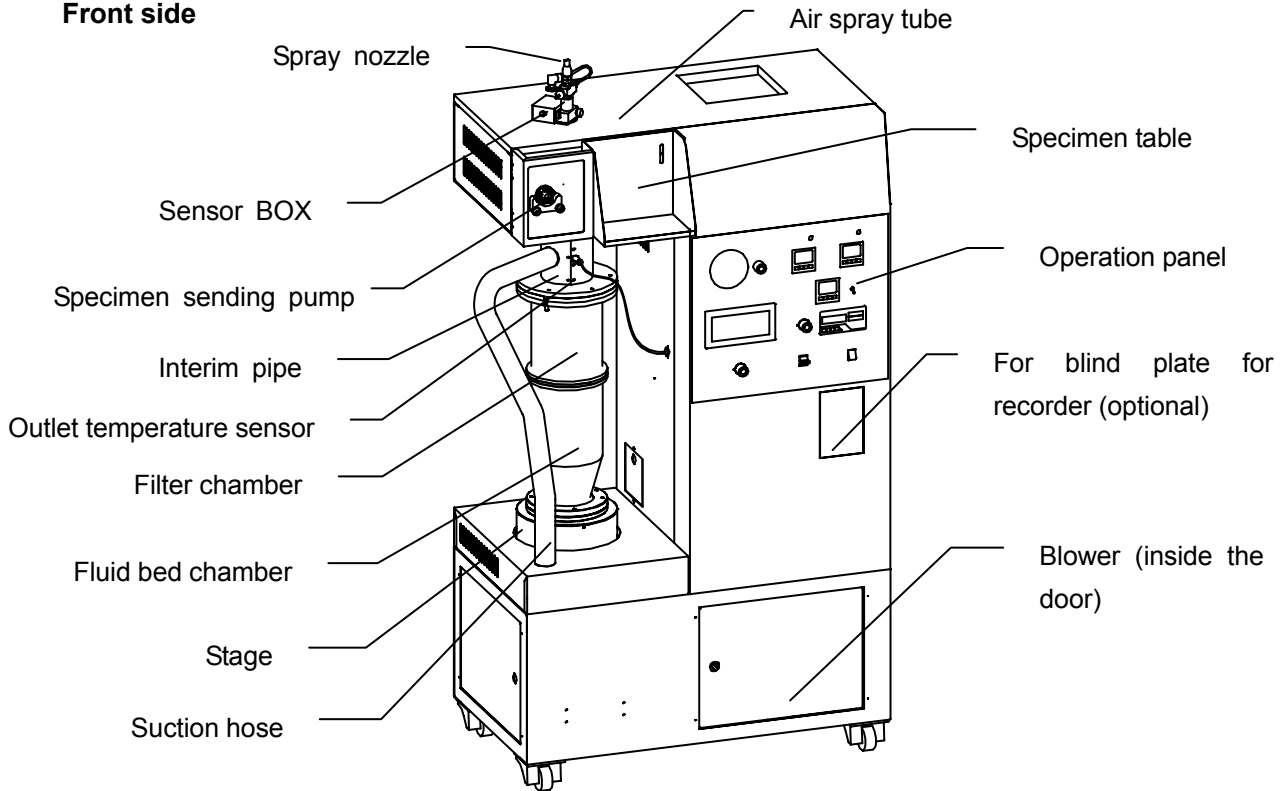

Rear side

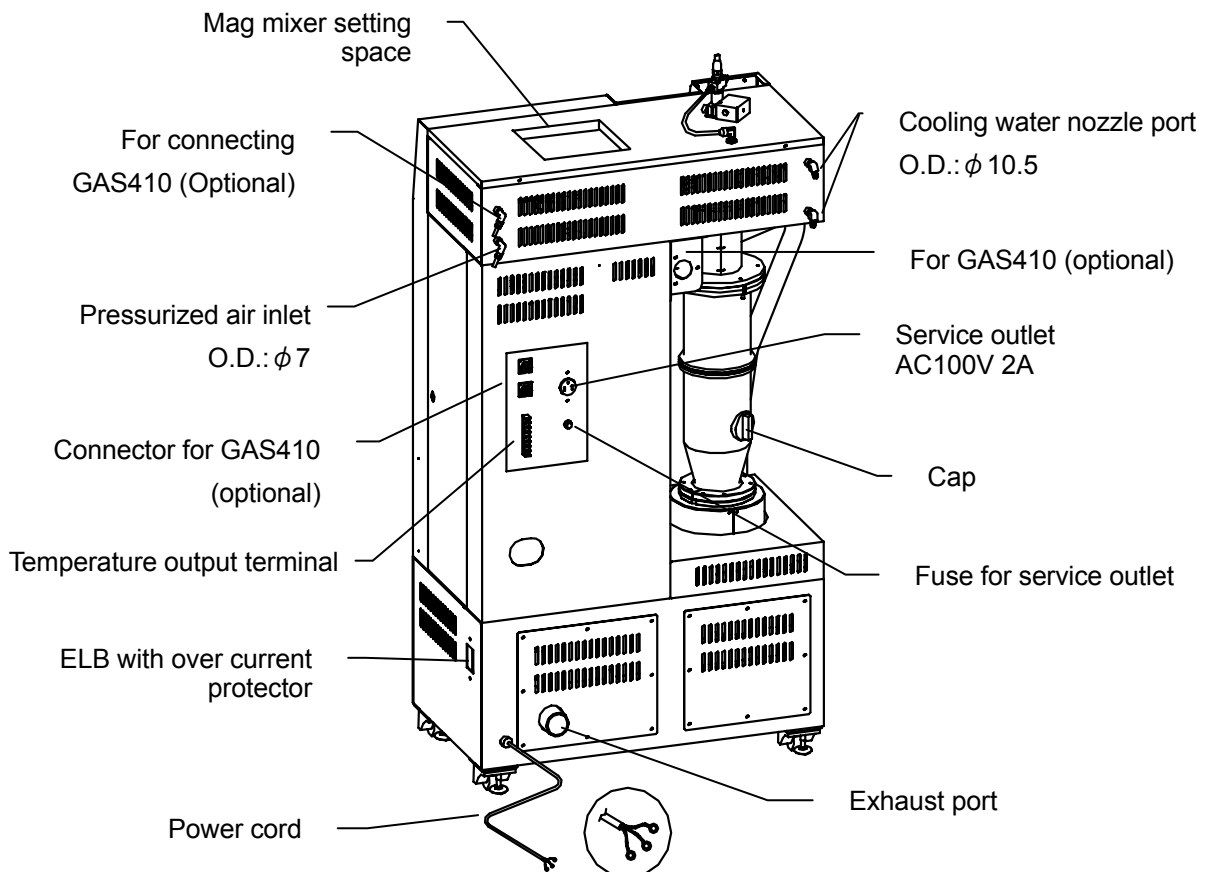

3.Names of parts and their function

Specifications of GB 210A (GB210 + GF300)

Front side

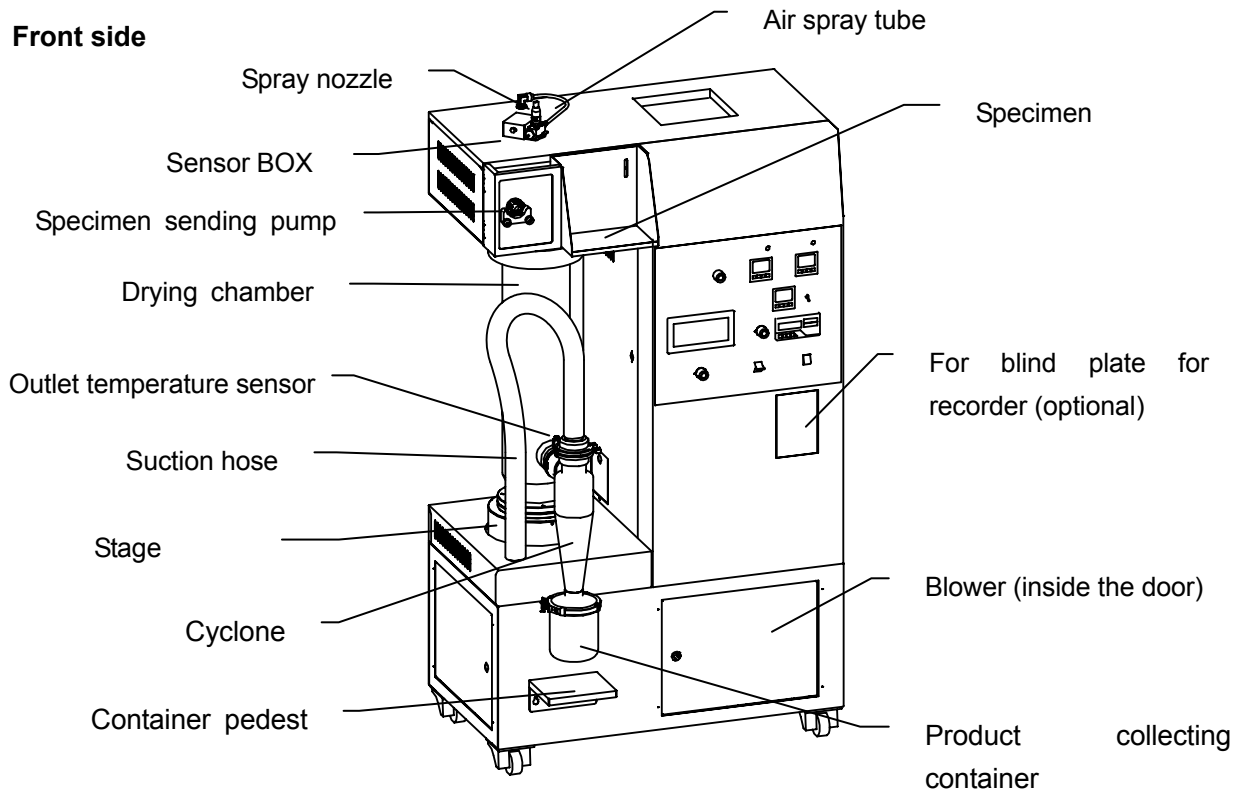

Rear side

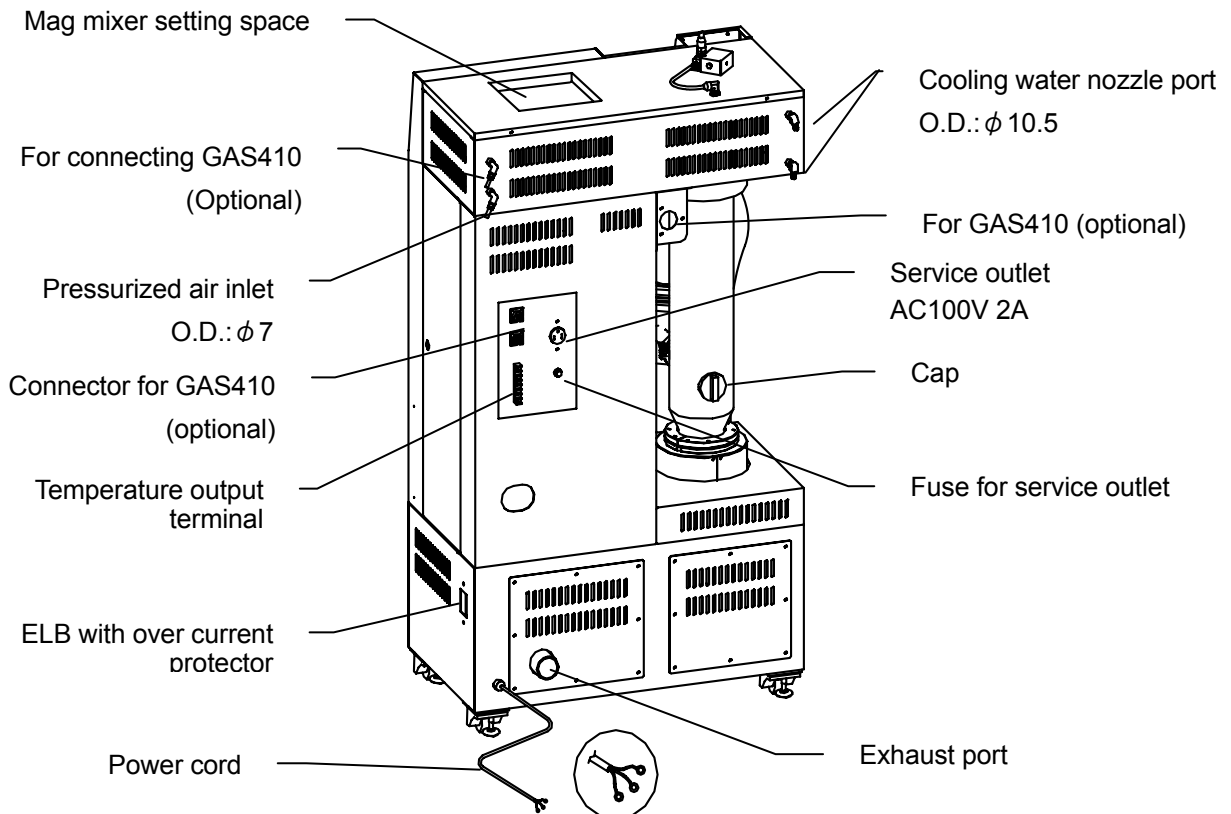

3.Names of parts and their functions

Operation panel

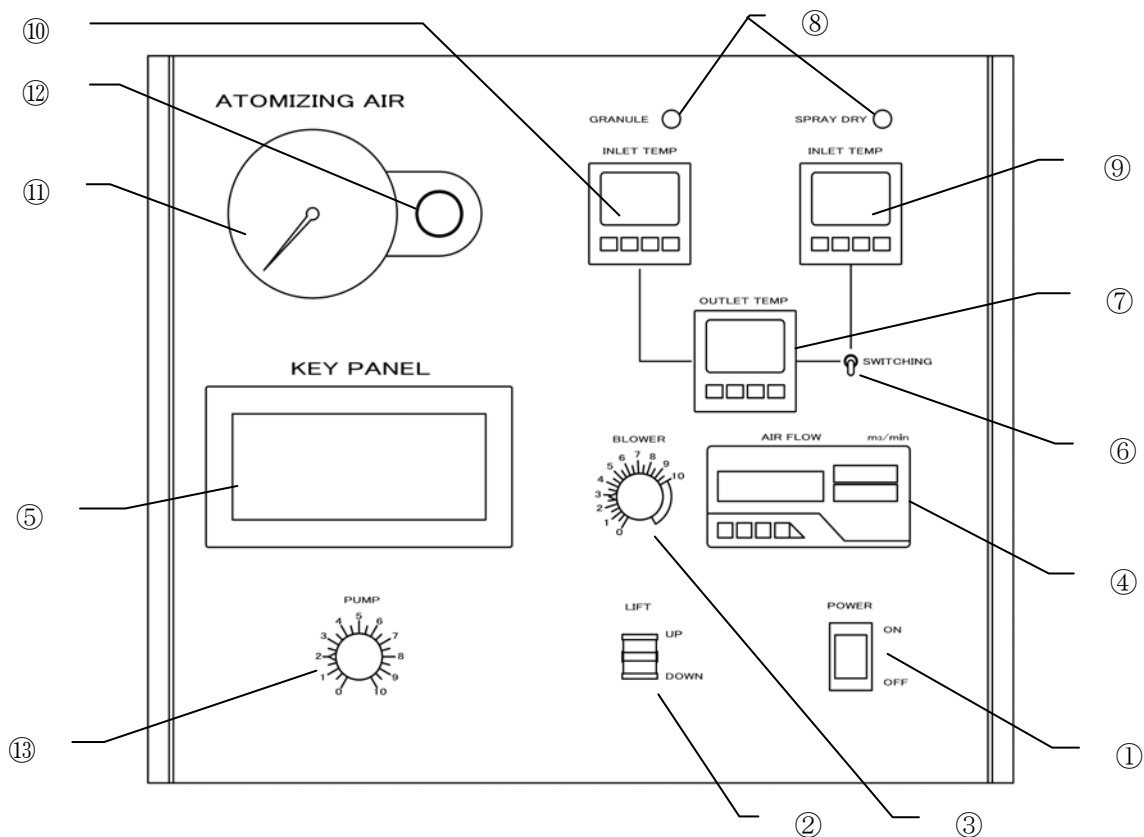

No.	Name	Operation/action
①	Power switch	This is used to turn power ON/OFF.
②	Lift switch	This is used to move UP/DOWN of the stage when an attachment is installed. This will automatically stop when it is subject to a certain amount of force.
③	Blower control dial	This is used to set an air amount.
④	Wind amount display	This displays an air amount.
⑤	Key panel (Touch panel)	This is used to perform the operations below and display. Blower ON/OFF, liquid pump FORWARD/REVERSE Heater ON/OFF, pulse jet switch Stirrer (stirring motor) On/OFF, error indication
⑥	Control selector switch	This is used to control temperature on the temperature controller on the selected side while this unit is being operated in specifications of the Mini Spray GB210A.
⑦	Setting and display of outlet temperature	This is used to display an outlet temperature. This is used to display and make settings in the GB210A specifications.
⑧	Display lamp	This is used to indicate the specification with which the suction filter installation status complies. GRANULE on : GB210B specification (Mini Bed specification) SPRAY DRY on : GB210A specification (Mini Spray specification)
⑨	Setting and display of mini spray inlet temperature	This is used to display the inlet settings and temperature when the mini spray is used.
⑩	Setting and display of mini bed inlet temperature	This is used to display the inlet settings and temperature when the mini bed is used.
⑪	Pressure meter	This meter indicates the pressure of pressurized air.
⑫	Needle valve control dial	This dial is used to control pressure of pressurized air.
⑬	Liquid sending speed control dial	This dial is used to control flow of the liquid pump.

4. Operating procedures

Preparations

- (1) Selecting the power supply (GB210A/GB210B)

! First switch the power supply terminal

First check that the switches of the control assembly and the ELB are OFF and then connect the power cord securely to the power supply meeting the specified voltage and current.

Ordinary, the unit has been specified to AC200V. Switch the terminals in the unit before connecting the power supply when you are going to use the unit in an AC220V or AC240V district. The terminal block is located inside the door at the right side. Refer P.13 "Exploded view of the suction port"

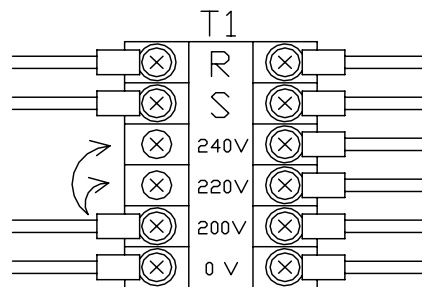

- (2) Connecting an earth (GB210A/GB210B)

The power cord of this unit is an earthed 3-core captive cable (VCT) that integrates an earth wire and you must earth the green wire.

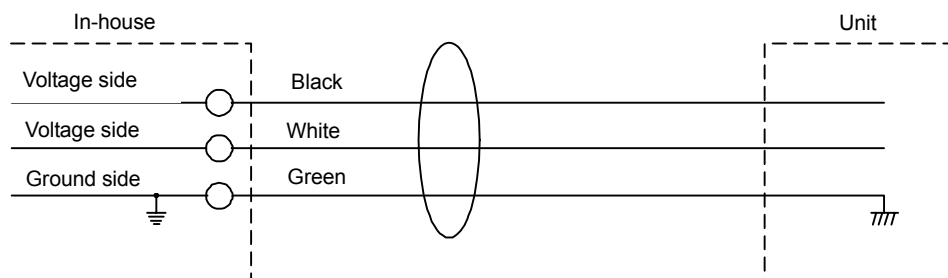

- (3) Connection of the exhaust duct (GB210A/GB210B)

In an environment where hot air or fine particles from the blower are of concern, connect the included exhaust duct to the exhaust port and use a draft chamber to exhaust them to outside.

- (4) Adjusting the sensor BOX position (GB210A/GB210B)

Because the GB210B spray nozzle has a nozzle fixing clamp, position of the sensor BOX shall be adjusted. Loosen the knurled screws at two positions and fix the sensor BOX so that it touches the spray nozzle.

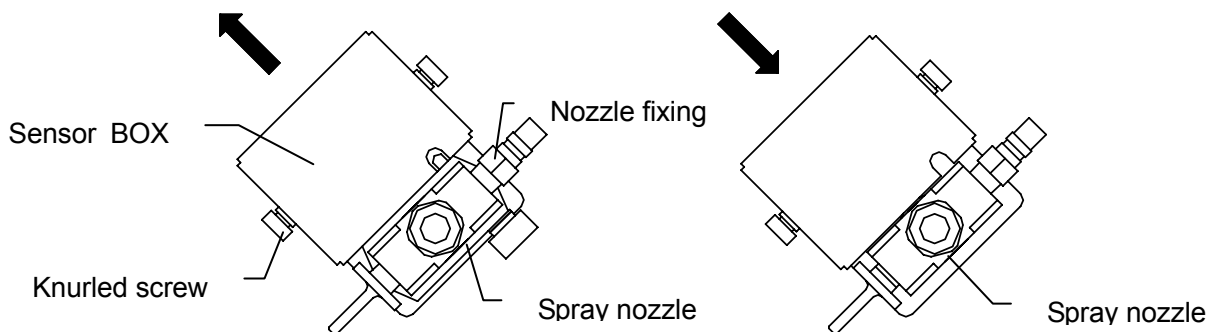

Drawing of the installed GB210B spray nozzle

Drawing of the installed GB210A spray nozzle

4. Operating procedures

Preparations

- (5) Connect the nipple ($\phi 7$) at the rear of the upper frame and the compressor or other pressurized air units with the included pressure-proof hose and then securely tighten it using a hose band. Adjust the discharge pressure of the compressor to be constant (0.3MPa or less) using the pressure reducing valve.

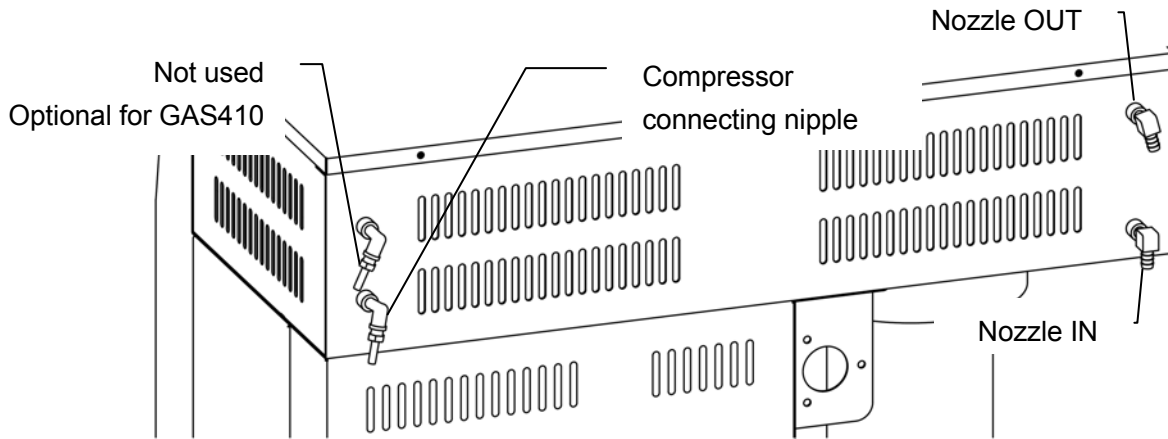

- (6) Cooling the spray nozzle (GB210A)

The cooling mechanism for the spray nozzle is pre-installed (nozzle O.D.: $\phi 10.5$). When you operate the unit under operating conditions under which the spray nozzle is likely to clog, connect a separate cooling water circulating unit (such as CF300) or to a tap water faucet to allow cooling water circulating.

Installation procedures of GB210B (GB210 main body + GF200 mini bed)

- (1) Remove four screws, open the right side door and check or switch the suction port connection point on the main body.

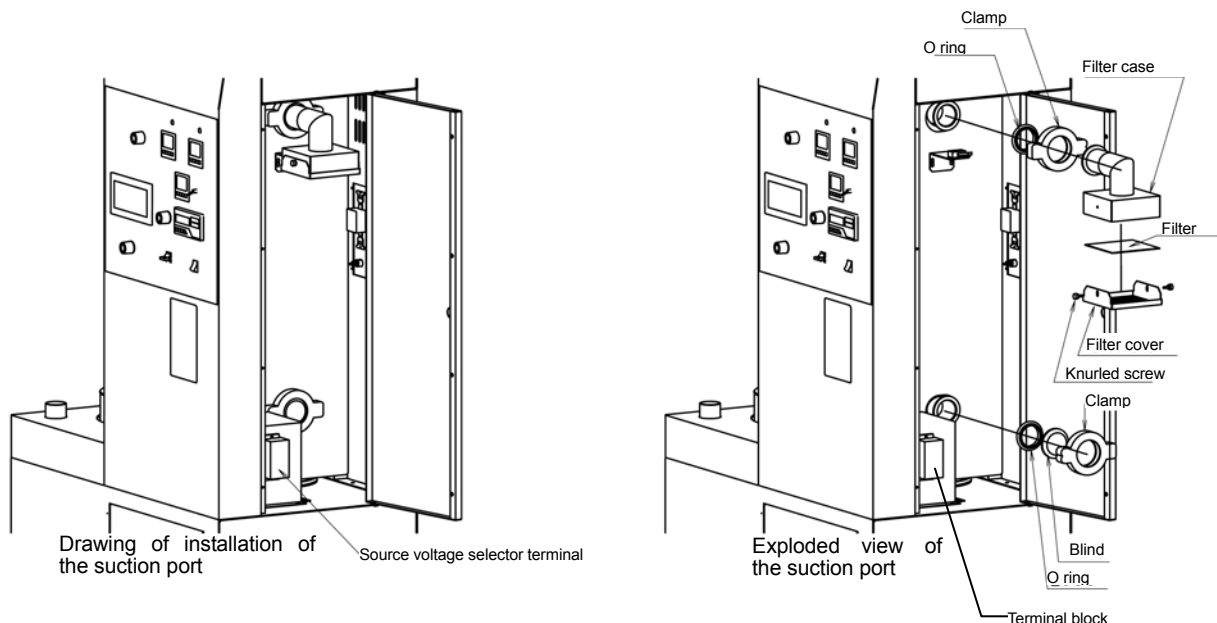

Make sure that the GRANULE lamp comes ON when you turn the POWER switch ON.

- (2) Unpack the mini bed attachment (GF200) and check for any broken glasses or missing parts.

4. Operating procedures

Preparations

- (3) Install parts following the procedures in the order of their numbers.

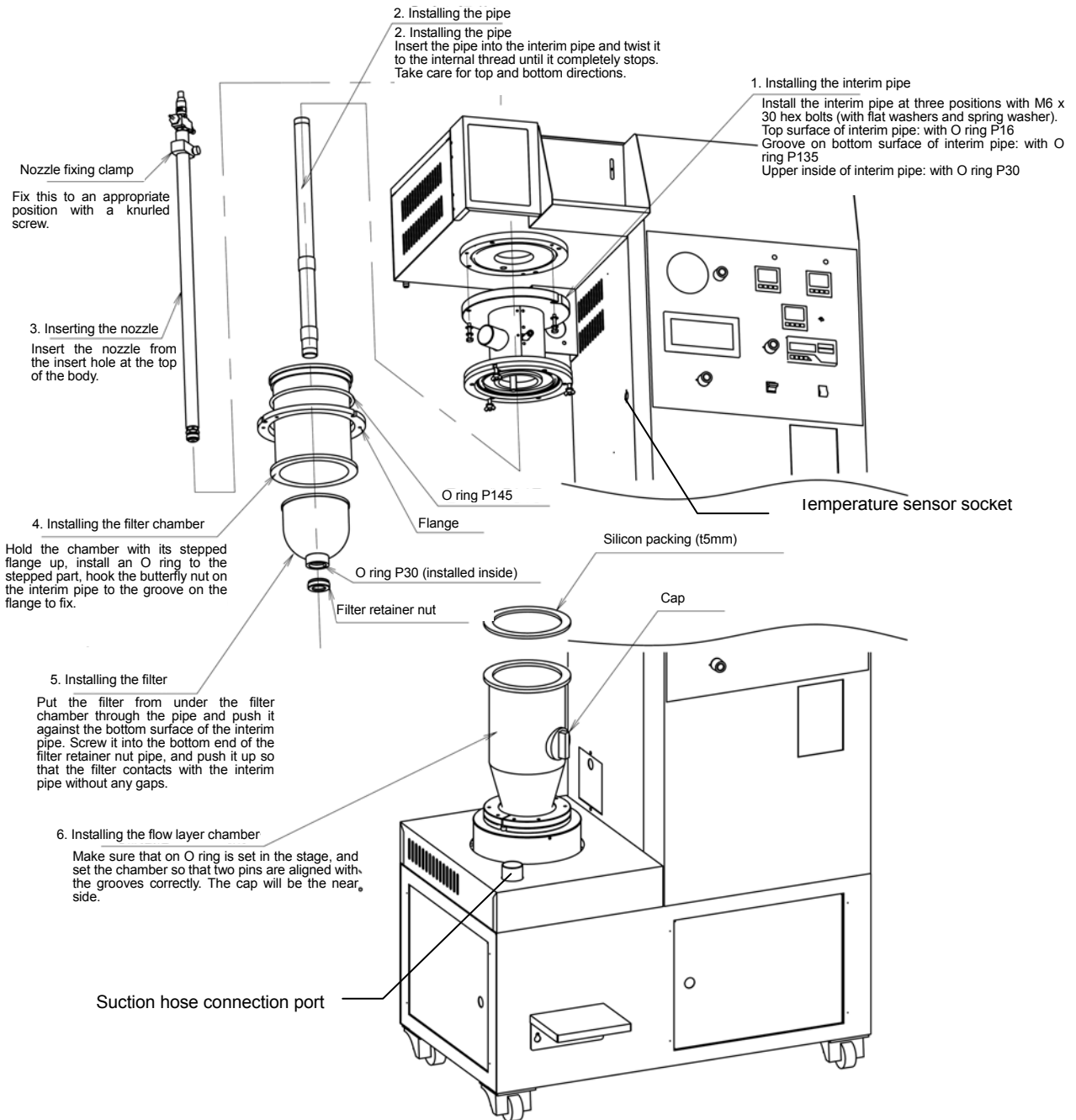

- (4) Turn the POWER switch ON and raise the stage with UP of the lift switch. Stop moving the stage once when the upper part of the flow layer chamber is close to the flange of the filter chamber, and then turn the UP switch ON intermittently until the top flange of the flow layer chamber is aligned with the packing and the flange of the filter chamber and the stage is stopped.
- (5) Install the temperature sensor to the pipe of the interim pipe and insert the plug into the socket on the side of the main body.
- (6) Install the suction hose to the pipe of the interim pipe and the pipe at the left front of the stage and fix them with hose clips.

4. Operating procedures

Preparations

Installation procedures of GB210A (GB210 main body + GF300 mini spray)

- (1) Remove four screws, open the right side door and check or switch the suction port connection point on the main body.

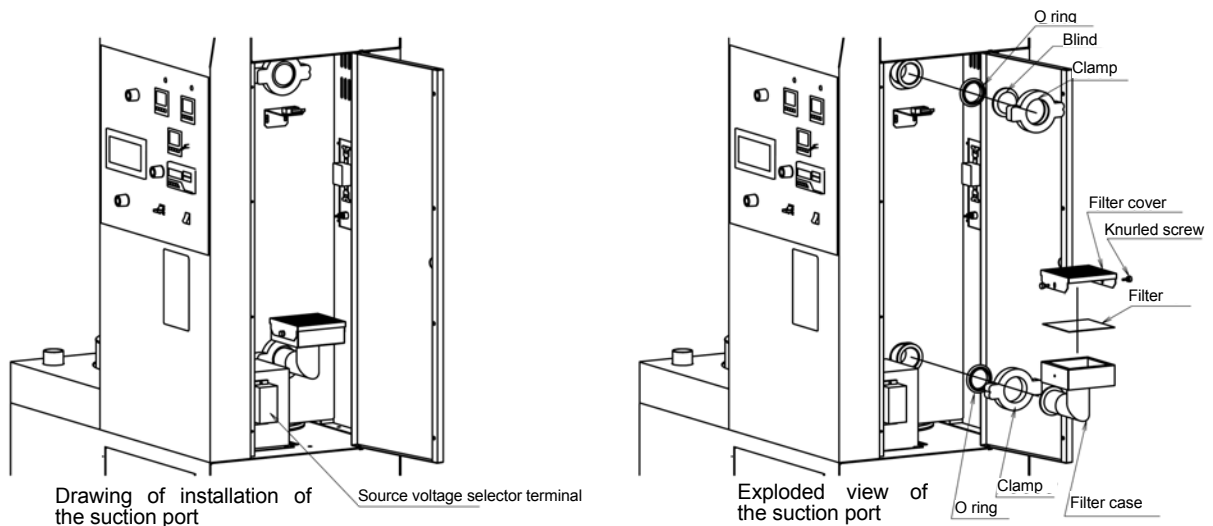

Make sure that the SPRAY DRY lamp comes ON when you turn the POWER switch ON.

- (2) Unpack the mini SPRAY attachment (GF300) and check for any broken glasses or missing parts.
- (3) Install the distributor and aluminum honeycomb assembly onto the top of the unit.
(install using three M6 x 20 hex bolts, spring washers, flat washers each)

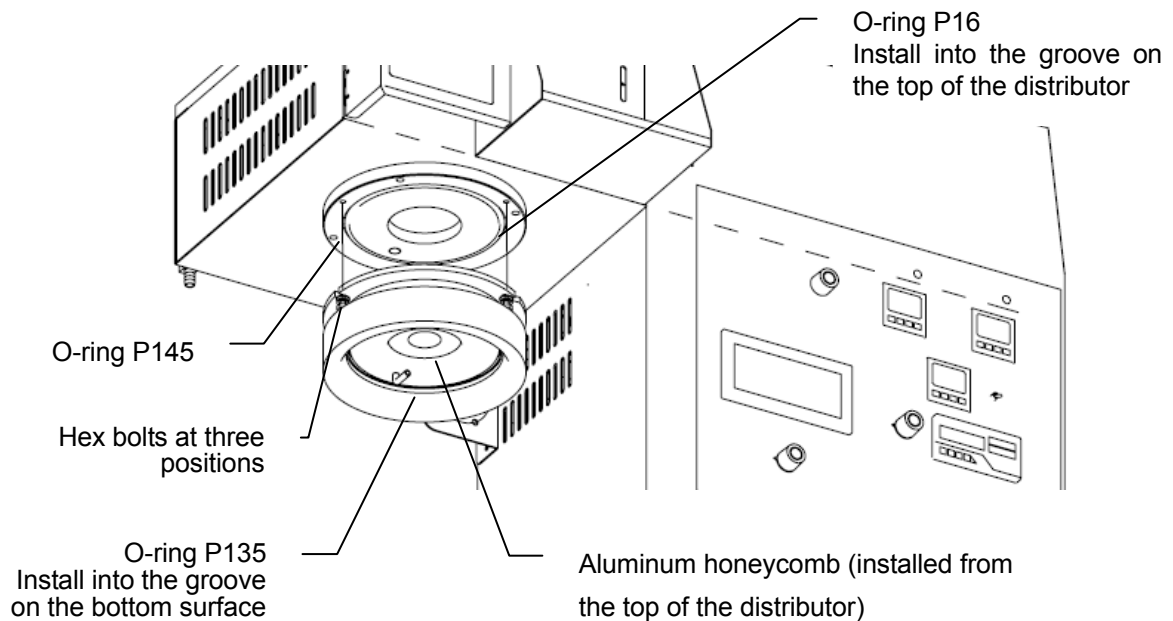

4. Operating procedures

Preparations

- (4) Insert the pipe in the center of the distributor and twist it all the way.

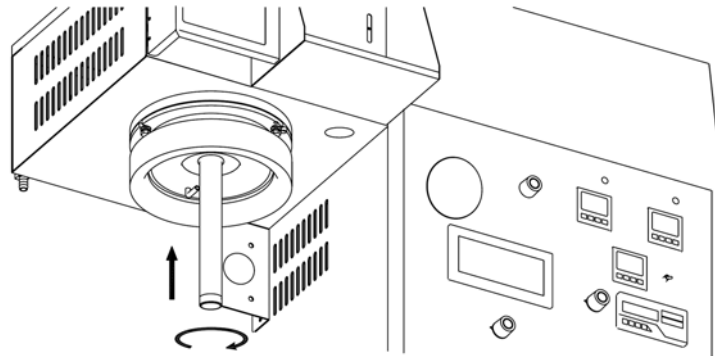

- (5) Install the container stand to the upper row of four taps at the front of the main unit with knurled screws.

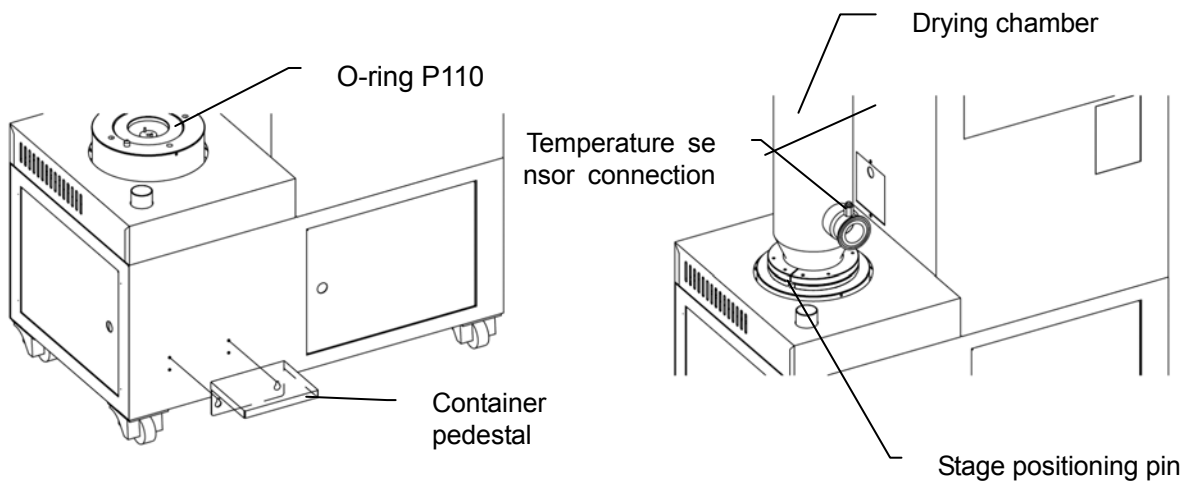

- (6) Install the drying chamber taking care to align the groove with the stage positioning pin.
Turn the POWER switch ON, raise the stage the stage with UP of the lift switch while holding the driving chamber with hand. Stop moving the stage once when the upper part of the drying layer chamber is close to the flange of the distributor, and then keep pushing the stage while turning the UP switch ON and OFF until the stage is stopped.
- (7) Install the outlet temperature sensor into the pipe at the glass container connecting port and insert the plug into the socket on the side of the main unit.

4. Operating procedures

Preparations

(8) Connect the cyclone following the step numbers below.

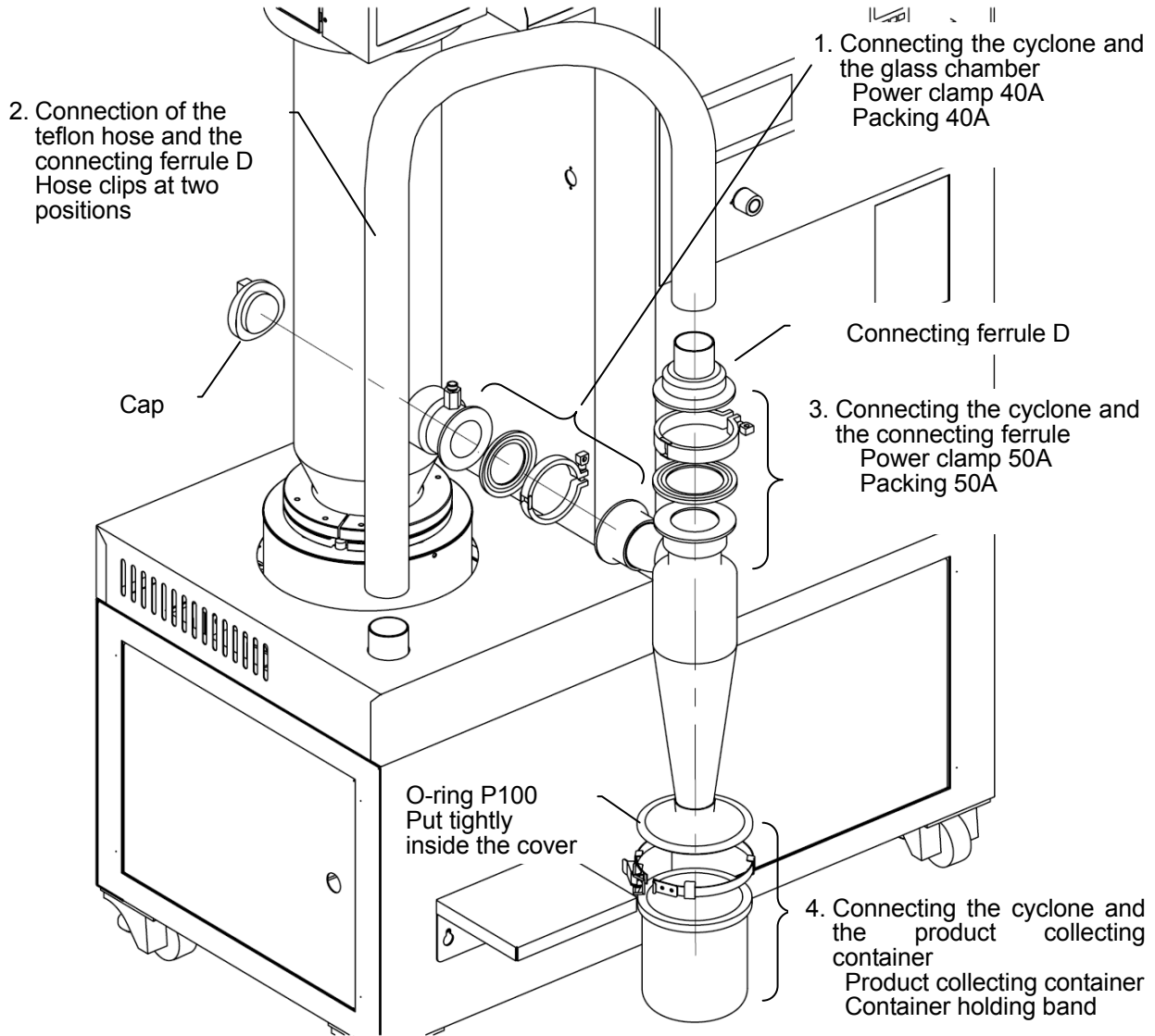

4. Operating procedures

Operating method

- (1) Turn the ELB on the right side of the main unit ON.

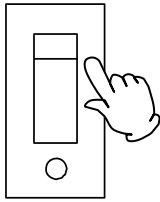

- (2) Turn the power switch on the operation panel of the main unit ON.
Temperature controllers, indication lamps, and the key panel will be displayed.

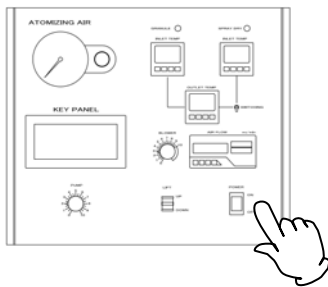

- (3) Check that the specifications correct for the application of this product are set on the display lamp.

- ※ To change the specifications, follow the installation procedures previously described (P.13 and P.15) to change the settings of the unit.

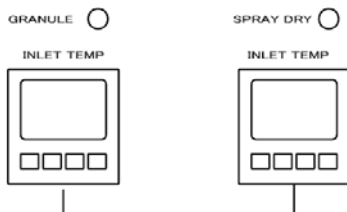

4. Operating procedures

Operating method of GB210B

Operating method of GB210B (GB210 main unit + GF200 mini bed)

Granulation method

Refer to sample settings for an example case for the standard sample.

Sintered alumina (W.A. #180) NET 300g

PVA (Polyvinyl alcohol) #500 NET 50g Solid component density 5wt%

- (1) The temperature controller at the upper left part of the operation panel is used as the display and setting device for inlet temperature and the lower temperature controller, as the display for outlet temperature.

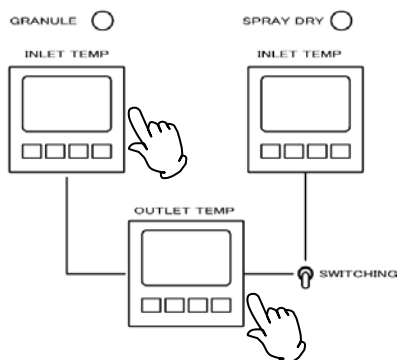

SWITCHING is not used when the mini bed is used.



- (2) Preliminary heating and setting of samples are performed here.
- (2) -1) Install mini bed attachments following the above procedures. Adjust the spray nozzle so that its tip will protrude below by about 30mm from the end of the pipe.
Set spray pressure to 0.01MPa.

- (2) -2) Turn the blower switch in the key panel ON.

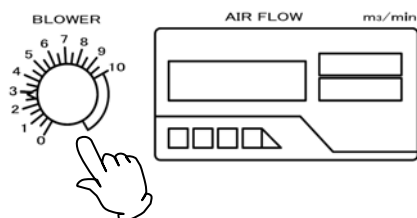

- (2) -3) Adjust the left volume so that an appropriate air amount is obtained while monitoring it on the air amount monitor.

Example Air amount: approx. 0.4m³/min

4. Operating procedures

Operating method of GB210B

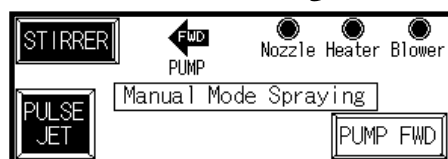
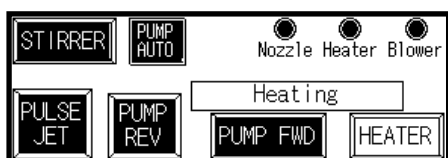
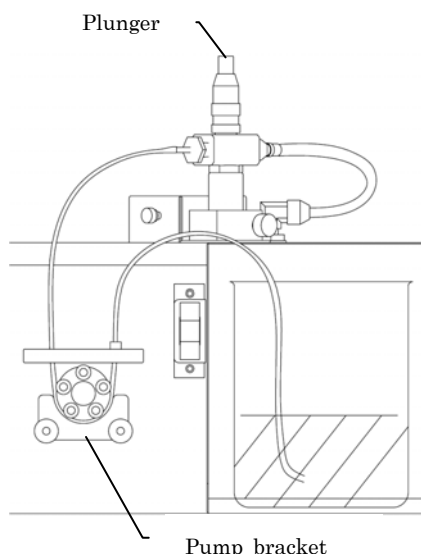
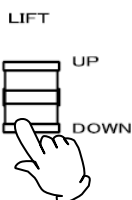

(2) -4) Set the inlet temperature. Then turn the heater switch ON to start heating.

Example Inlet temperature setting: 120°C

(2) -5) When outlet temperature has become stable, turn the heater switch and the blower switch by performing procedures in (2) -2)、(2) -4) in the reversed order.

Example Outlet temperature: Stable at approx. 60°C

(2) -6) Turn the lift switch DOWN, remove the flow layer chamber, and put sample evenly on the micro pore plate.

※Be sure to wear heat resistant gloves when handling the flow layer chamber, which may be very hot.

Example Sample: sintered alumina 300g

(2) -7) Set the flow layer chamber to the main unit again following the installation procedures in (3) -6), (4) on P.14 above.

(2) -8) Setting the liquid sending tube

Set the liquid sending tube as shown in the left diagram and then secure the tube, which is made flat with the pump bracket, with a knurled screw.

※When any sample is not sprayed any more, which may indicate clogging of the spray nozzle orifice, push the plunger at the upper part of the nozzle (P33. “Cleaning After Using” Exploded view of the spray nozzle). The needle (P33. “Cleaning After Using” Exploded view of the spray nozzle) will push out the foreign object in the orifice.

(2) -9) Place the liquid sending tube in a container that contains binder, turn the pump FWD switch ON, and when the binder is close to the nozzle inlet, turn the pump FWD switch OFF. At this time, adjust the liquid sending speed of the pump to an appropriate setting.

Example Binder : polyvinyl alcohol 50g

(Actually used amount is approx. 20g)

Adjust the liquid sending speed to 12mL/min.

4. Operating procedures

Operating method of GB210B

Types and features of binders (reference material)

Types	Features
Gelatin	This has only a weak binding force at a lower concentration and high concentration solution shall be sprayed with humidification.
Dextrin	This has only a weak binding force but is superior in molding capability into tablets.
Potato starch	This is superior in granule property and inexpensive. Utilized in medical and food fields.
Sodium alginate	This has a high viscosity and is suitable as a binder mainly used in the food field.
Gum Arabic	Shall be humidified for spraying. This requires a lot of binder.
CMC (Sodium Carboxymethyl Cellulose)	This presents a higher viscosity at a lower temperature. This tends to leave considerable powder residues.
HPC(Hydroxypropylcellulose)	This is suitable for cohesive, hydrophilic materials.
MC (Methyl Cellulose)	This has a strong binding force and is suitable to those used for granules coarser.
PVA (Polyvinyl alcohol)	This is superior in granulation efficiency but has some shortcomings in degradation of granulated substances.
PVP (Polyvinylpyrrolidone)	Those with a higher molecular weight have a strong binding force and are appropriate for hydrophilic materials.

- (3) Follow the same procedures as for the preheating to start operation of the blower and the heater and start flowing sample. Adjust air amount with the blower adjusting dial so that the height of the flow layer coincides with the silicon cap position on the flow layer chamber.

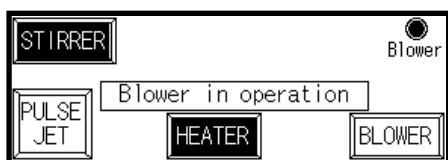

~Operational hint~

Too much attachment of fine powder on the filter may decrease air amount. Press the pulse jet switch on the key panel to blow pressurized air into the filter to remove fine powder off. Press the pulse jet switch at a regular interval to minimize attachment of fine powder onto the filter.

ATOMIZING AIR

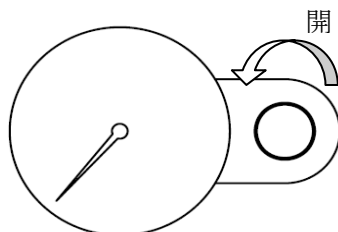

- (4) When the outlet temperature has stabilized, set a spray pressure and turn the pump FWD switch ON.

Example Spray pressure 0.04MPa Liquid sending speed: 12mL/min

When flow of sample slows down, turn the pump FWD switch OFF to reduce spray pressure to minimum.

(Completely shutting spray pressure may cause clogging of the nozzle.) To prevent the nozzle from clogging, use the pump REV switch to return binder to a point close the tube connection port on the nozzle. The pump REV switch is active while it is pressed.

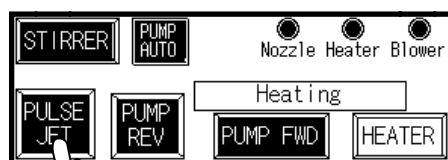

Example Turn the pump switch OFF about 30 seconds after starting spraying.

Reduce spray pressure to 0.01MPa.

4. Operating procedures

Operating method of GB210

(5) Repeat spraying and drying operations in step (4) until granule diameter you want is obtained.

Granule diameter will become gradually larger in the second session of spraying and drying and after, and thus you need to gradually shorten time of binder spraying and gradually increase air amount.

Example Repeat spraying and drying of polyvinyl alcohol five times. (Approx. 20g is used in total)



~Operational hint~

When flow of samples has degraded, either increase blower air amount or press the stirrer switch in order to disperse the samples evenly to always keep good flow conditions. And when the spraying is unstable, press the upper tip of the nozzle to remove clogging at the nozzle tip. The stirrer switch is active while it is pressed. Press the switch for three seconds or more if you want to operate continuously. Press it again to cancel continuously operation. The stirrer will also stop when the blower is turned OFF.

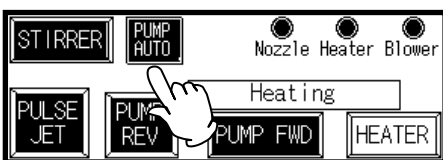

《Useful functions》

The pump can be operated in the auto mode only when conditions for spraying and drying time can be quantified in operations of (4) and (5).

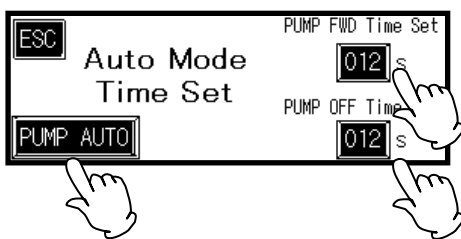

Operating procedures

- a) Press the PUMP AUTO switch.
- b) Set pump FWD operation time and pump OFF time.
Touching the Time Set key will display a numeric keypad. Enter numeric values and press "ENT" to determine the entered time.
Time can be set in the range of 1–600 seconds and when you enter a numeric value outside this range and press "ENT", it will be changed to the upper or lower limit automatically.
- c) Start automatic operation of the pump using the PUMP AUTO switch.
- d) To stop automatic operation, press the PUMP AUTO switch and then the ESC switch.

			10	ESC
7	8	9	0	AC
4	5	6	+/-	DEL
1	2	3	.	ENT

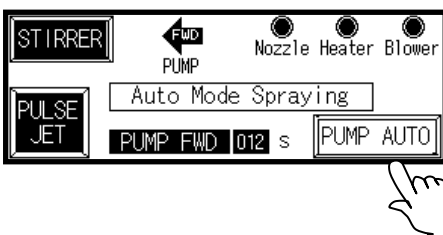

4. Operating procedures

Operating method of GB210

ATOMIZING AIR

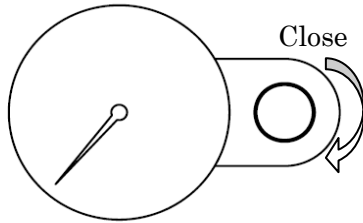

- (6) When the sample reaches the granule diameter you want, sufficiently dry the samples, and turn the heater OFF. When outlet temperature has decreased to 45°C or lower, turn the blower OFF and choke spray pressure to 0.

※To avoid a malfunction of the unit, do not turn the blower OFF while the outlet temperature is 45°C or more.

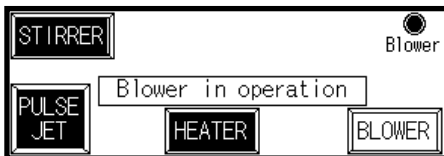
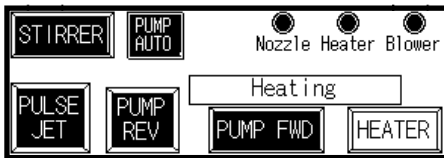

- (7) Using the pulse jet switch, remove foreign objects off the filter.

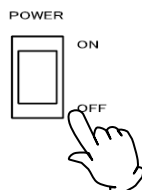
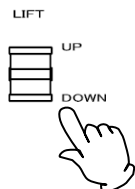

- (8) Lower the stage with the lift DOWN switch and then turn the POWER switch OFF.

Take out the flow layer chamber and collect the granulated samples.

- (9) Wash the containers according to the maintenance method (P33 and following pages "Cleaning After Using").

4. Operating procedures

Operating method of GB210B

Drying operation of moist powder

※Drying operation of moist powder does not use the liquid sending pump and spray pressure.

- (1) Put sample evenly on the micro pore plate in the flow layer chamber and set the chamber to the main unit following the installation procedures in (3) -6), (4) on P.14 above.
- (2) Referring to procedures for granulating operation, set the nozzle ((2)-1) , operate the blower ((2)-2) , adjust air amount ((2)-3) , operate the heater ((2)-4) , and perform drying operation of samples. Adjust air amount with the blower adjusting dial so that the height of the flow layer coincides with the cap position on the flow layer chamber.

~Operational hint~

Too much attachment of fine powder on the filter may decrease air amount. Press the pulse jet switch on the key panel to blow pressurized air into the filter to remove fine powder off. Press the pulse jet switch at a regular interval to minimize attachment of fine powder onto the filter.

When flow of samples has degraded, either increase blower air amount or press the stirrer switch on the key panel in order to disperse the samples evenly to always keep good flow conditions.

- (3) The outlet temperature decreases once drying of sample is started and resume increasing when water content in the sample become less. Drying finishes when flow status of sample improves and increase of outlet temperature almost saturates.
Follow procedures in (6) ~ (8) for granulation operation to stop operation and take out the sample out of the flow layer chamber.
- (4) Wash the containers, the spray nozzle, and filters according to (P33 and following pages “6. Maintenance method”) after using the unit.

4. Operating procedures

Operating method of GB210B

Operating method of GB210A (GB210 main unit + GF300 spray attachment)

Spray drying operation method

Refer to sample settings for an example case for the standard sample.

Sodium chloride solution NET 100g Solid component concentration 5wt%

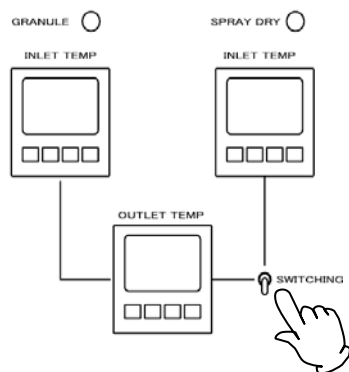

- (1) The temperature controller at the upper right part of the operation panel is used as the display and setting device for inlet temperature and the lower temperature controller, as the same device for outlet temperature. The temperature controller at the upper left part is not used.

You select temperature control for inlet or outlet temperature using SWITCHING. When you want to control temperature by the outlet temperature, select inlet temperature at the start of operation switch to outlet temperature once the temperature has stabilized.

Example: Select the inlet side with SWITCHING

Inlet temperature setting: 150°C

- (2) Install the mini spray attachment following the procedures above (P.15~P.17).



- (3) Turn the blower switch ON and set air amount.

Example: Air amount 0.45m³/min

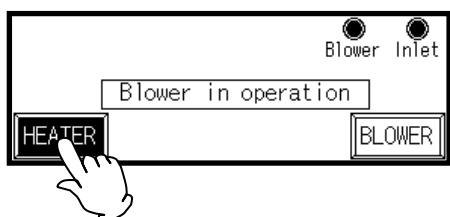
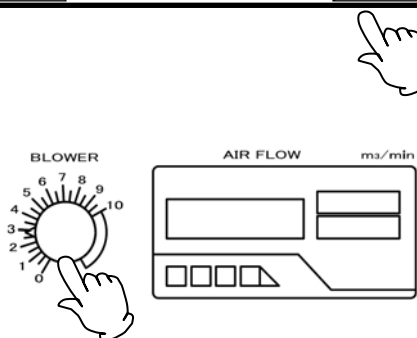

- (4) Turn the heater switch ON.

4. Operating procedures

Operating method of GB210B

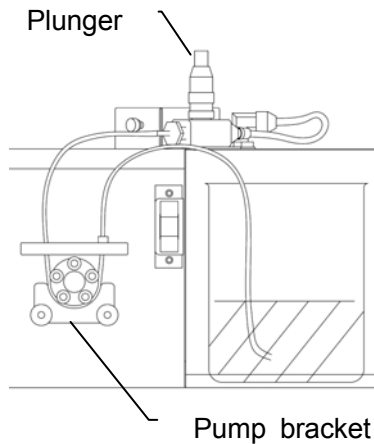

- (4) Set the liquid tube as shown in the left diagram and fix the tube with flattened with the pump bracket. Set distilled water as the specimen.

Example: Specimen of distilled water set

- * **When specimen is not sprayed any more, it is suspected that the orifice of the spray nozzle is clogged, which can be cleared by pressing the plunger at the upper part of the nozzle (P33." Cleaning After Using "Exploded view of the spray nozzle). The needle (P33. "Cleaning After Using "Exploded view of the spray nozzle) pushes out the clog in the orifice.**

ATOMIZING AIR

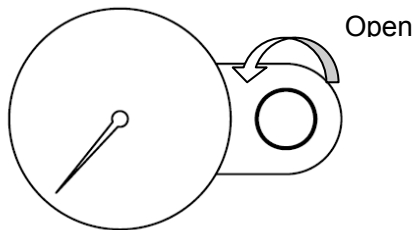

- (5) When the inlet and the outlet temperatures have reached the temperatures you want, set the spray pressure, turn the pump FWD switch ON and send distilled water.

Example: Set the spray pressure to 0.1MPa when the outlet temperature has risen to around 80°C. Adjust liquid sending speed so that the outlet temperature will be slightly lower than about 75°C.

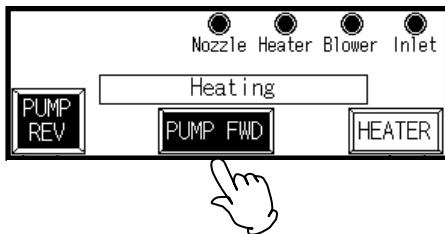

- (6) Readjust dry air amount, spray pressure, and liquid sending speed so that the inlet and the outlet temperature will be stable at the temperatures you want.

Example: Adjust liquid sending speed so that the outlet temperature will be stable at around 75°C or slightly lower temperature.

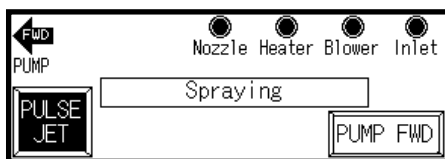
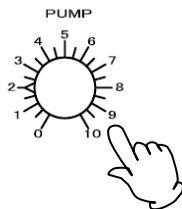

~Operational hint ~

- Influences below are of specific settings on the outlet temperature when the inlet temperature is constant.
 - Sent specimen liquid amount
 - small : outlet temperature →high
 - Dry air amount
 - large : outlet temperature →high
 - Specimen density (external factor)
 - high : outlet temperature→high
- Drops of sprayed liquid will become fine at a higher spray pressure.

4. Operating procedures

Operating method of GB21

- (7) When the outlet temperature has become stable, change the specimen with the actual one. At this time the outlet temperature will change slightly and adjust liquid sending speed again when necessary.

Example: Change specimen to 100g of 5% sodium chloride solution

- (8) When specimen has been sent, change the specimen back to distilled water and clean inside the nozzle. Clean inside the nozzle for about five minutes, turn the pump FWD switch OFF, and then choke the spray pressure to 0.

Example: When processing of 100g has finished after about 15minutes, change the specimen to distilled water.

ATOMIZING AIR

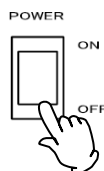
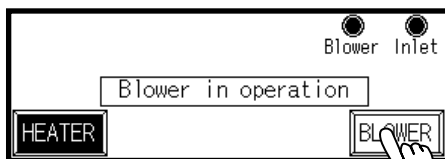
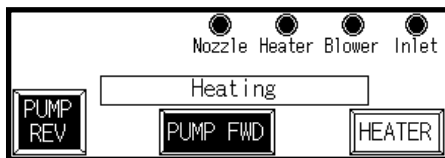
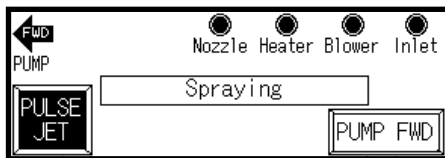
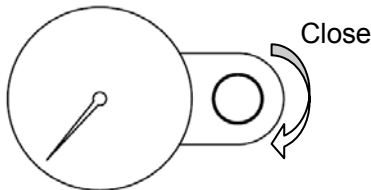

- (9) Turn the heater OFF, wait until the outlet temperature drops to 45°C or less, and turn the blower OFF.

* **To avoid a malfunction, do not allow the blower operation stopping with the outlet temperature at 45°C or over.**

- (10) Turn the power switch OFF.
 (11) Remove the container holding band and take out the product collecting container. When taking out the container, take care the powder attached on the back side of the cyclone cover.

Example: Amount of collected powder will be about 3 to 3.5g.

- (12) Wash the containers according to the maintenance method (P33. "Cleaning After Using").

* **When you used a sample such as sodium chloride that corrodes metals, disassemble the spray nozzle and wash thoroughly.**

4. Operating procedures

Operating method of GB210A/GB210B

KEY PANEL Description of indication lamps

You can confirm the operating statuses of switches one the KEY PANEL by checking whether a specific lamp is on or off.

Each lamp will be turned on at the upper right corner on the KEY PANEL.



Nozzle

Lamp on: Indicates that the spray nozzle is attached.

Lamp blink: Indicates that a spray nozzle is not attached.



Outlet

You can control temperature by setting a temperature on the outlet side temperature controller while the lamp is on.

* The lamp is on only when GB210A specifications is used.



You can control temperature by setting a temperature on the inlet side temperature controller while the lamp is on.

* The lamp is on only when GB210A specifications is used.



Blowe

When the lamp is on, the blower is in operation.



Heate

When the lamp is on, the blower is in operation.



When the lamp is on, the liquid sending pump is operating in the normal direction.



When the lamp is on, the liquid sending pump is operating in the normal direction.

When you want to stop processing of a sample or the nozzle is clogged

Stop sending liquid with the following operations in "Operation method of GB210B".

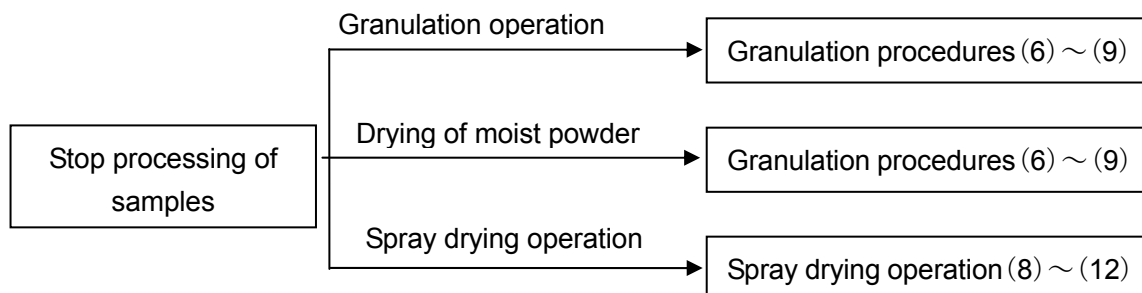

If you want to process another sample, collect contents in the product container, clean it following the maintenance procedures (P33 and following pages "6. Maintenance method"), and then operate the unit with another sample.

5. Handling Precautions

Warning

1. Substances that cannot be used



Never use an explosive, a flammable, or a substance that contains them. Otherwise, an explosion or a fire may result. **GB210A supports organic solvents by connecting it to the optional GAS410. Carefully read the operation manual of GAS410 and take special care for handling of organic solvents.**

See P.56 "15. List of Dangerous Substances".

2. If a problem occurs



If smoke or strange odor should come out of this unit for some reason, turn off the power key right away, and then turn off the circuit breaker and the main power. Immediately contact a service technician for inspection. If this procedure is not followed, fire or electrical shock may result. Never perform repair work yourself, since it is dangerous and not recommended.

3. Do not touch the part with high temperature



The chamber, cyclone, and peripheral part become high temperature during and just after operation. Do not touch these parts, for there may be caused heat injury.

Caution

1. Do not put anything on this unit



Do not put anything on this unit. It will cause injury if fall.

2. During a thunder storm



During a thunderstorm, turn off the power key immediately, then turn off the circuit breaker and the main power. If this procedure is not followed, fire or electrical shock may be caused.

3. Recovering after power failure



When the unit stopped due to a power outage during operation and power was supplied again, the unit resumes operation at the status immediately before the outage.

4. After installing



It may cause injure to a person if this unit falls down or moves by the earthquake and the impact, etc.. To prevent, take measures that the unit cannot fall down.

5. Handling Precautions

Drying Method under Appropriate Condition

Items for GB210A

- (1) The best appropriate drying condition is differed depending on the sample to be dried. Inquire the data for the partial example of various samples.
- (2) Adjust the drying condition so as to match to the various errors to be possible to occur such as too much adhesion of the sample to the drying chamber, too high density of the sample, too low temperature around inlet, too high or too low pressure of spray air, too much feeding amount of sample.
- (3) When the spray direction is changed by the adhesion of the sample to the spray nozzle during operation, turn "ON" the pulse jet switch, and blowout the adhesive from the tip of the nozzle using pressurizing air. Even though the adhesive is not blowout, dismount the spray nozzle, and clean the tip of the nozzle using the soaked paper in water.
- (4) The possible cause for adhesion of the sample to the cyclone part is either not evaporating the solvent (distilled water or ion-exchanged water) with enough or the property of the sample itself (low melting point, absorption, etc.).

For depleting the powder, increasing the amount of heat for sample is the best measure. Therefore, perform either measure below, to increase either temperature around inlet or flow rate of the drying air, or to reduce the feeding amount of the sample, that is, to reduce the difference between the temperature around inlet and that around outlet. When the reason is in the property of the sample itself, adjust the sample by adding the special additive, etc.

(5) In the case that the hygroscopicity is high, the product may become the moist powder in the container. Change the drying condition following the method in (4), or, if required, heat up the container for product before operation.

- (6) The orifice of the spray nozzle is 460 μ . If the sample is blocked with suspension at orifice part impetuously, use the 508 μ and 711 μ nozzles prepared for the orifice as optional (Nozzle main body P33." Cleaning After Using ",the nozzle main body, the needle, and the ring in the exploded view of the spray nozzle are common with the 406 μ nozzle) These 508 μ and 711 μ nozzles are differed on the point of the size of the spray pattern and particle diameter of the drop slightly compared to the 406 μ one, and these differences may affect the interference status. Refer to the Graph 1 for the relation between spray air pressure and spray airflow rate (atmospheric conversion).

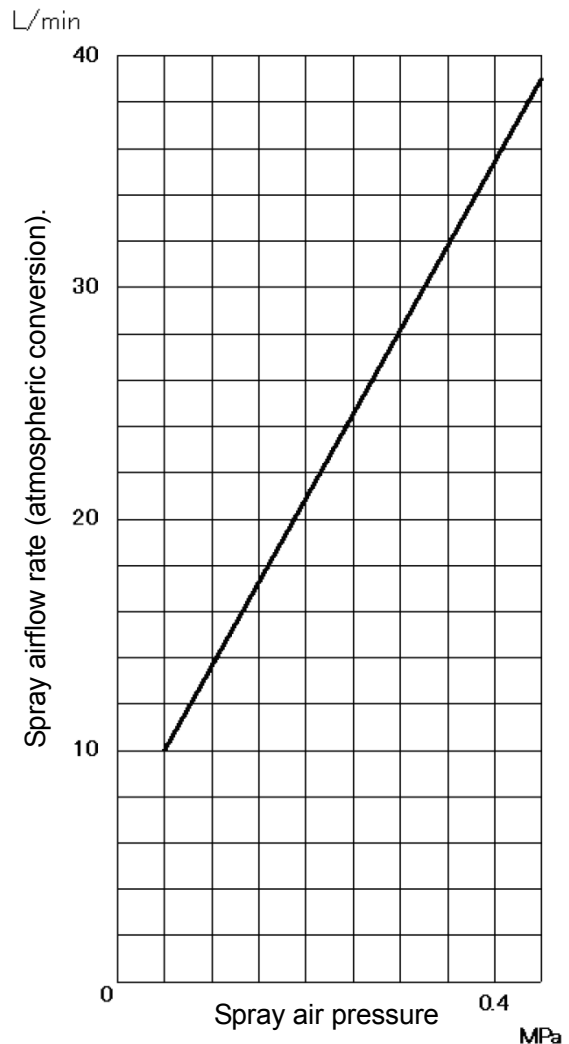

- (7) The too small powder (few μ or less) among dried ones is impossible to be collected, and exhausted to the outside through the blower. If this exhausted amount of the too small powder becomes more, decrease either spray airflow rate or spray air pressure. Also, since the particle diameter becomes smaller as the density of the sample is lower, adjust the density of the sample if required.

5. Handling Precautions

Drying Method under Appropriate Condition

Items common for GB210B/210A

- (1) Never fail to connect the earth terminal. If not, the electric leakage breaker will not activate in case a malfunction occurs and will present an extreme danger.
- (2) Be sure to confirm that the attachment you are using matches the indication of GRANULE or SPRAY DRY before starting operation.
- (3) Keep the pressurized air from the compressor at 0.3MPa or less.
- (4) Do not heat up the temperature around outlet over 100 Celsius degree, for the material of the suction/exhaust hose, material of the filter, and performance of the blower may be deteriorated. The heater will stop automatically when the temperature exceeds 110°C.
- (5) Check the glass chambers are fixed to the specified position with no gap, and then turn on the switches of blower and heater.
- (6) The unit is not explosion proof. Do not use any solvent that contains flammable organic solvents for the specimen.
- (7) If you want to use an organic solvent under the GB210A specifications, connect and use an optional (GAS410) organic solvent collection unit.
- (8) When the heater is ON, do not expose the cap and bayonet of the spray nozzle to the non-guard status, and do supply the air to the heater part for at least 0.1 to 0.2m³/min.。 Abnormal heating of the heater will activate the overheat prevention function or may result in a heater disconnection or other troubles.
- (9) When the sample is not sprayed, the orifice of the spray nozzle is considered as blocked. Press the plunger of the upper nozzle (P42." Cleaning After Using" spray nozzle exploded drawing). The needle pushes out the clogging of the orifice.
- (10) If the sample is not fed from the feeding pump, the following causes may be considered; the sample tube is crushed at the roller of the pump, the inner wall of the tube is adhered tightly without restoration, or the inner of the nozzle is blocked. Remove the cause, and reset to the normal status.
- (11) Do not perform unattended operation during activating the unit. Since the unit is in idling status and the nozzle is blocked of after the operation using sample, the temperature around outlet is increased and the remaining sample is flown from the sample tube disconnected from the unit, and these failures may cause the indeterminism accident.
- (12) Sample tube made of silicon or Tiron is oxidized by halogen solenoid or acid (strong), and may be broken by swelling. Therefore, pay attention to the treatment during operation.
- (13) When the high temperature is set to the temperature around inlet for the operation, supplying too excessive airflow of the blower to the unit may not reach the temperature to the setting one caused by not keeping balance with the heater capacity. To resolve this error, turn down the airflow of the blower, increase the setting temperature, and operate this unit. Also, set air amount below the red zone on the dial scale to avoid possible failures of the blower. The setting and the actual inlet temperature may not match when the unit is operated at a higher set temperature. Note that the heater will automatically stop when the inlet temperature exceeds 230°C.
- (14) If this unit is not operated, turn "OFF" the earth leakage breaker on the back of the unit.

5. Handling Precautions

For GB210B

- (1) At a large air amount, the effect of the pulse jet will be compromised and the amount of powder attaches onto the filter will increase. If you need to remove it, lower the air amount once before using pulse jet.
- (2) When amount of foreign objects is large at the upper part of the filter chamber and the flow layer chamber, simply tap them lightly to remove them. If those objects are stubborn, remove the cap of the flow layer chamber as necessary and remove them using a spatula.
- (3) When amount of powder or most powder put in the chamber is large, the stirrer blades may not rotate even when you turn the stirrer switch ON. In that case, to avoid a malfunction of the motor from over load, do not use the stirrer switch but stir inside the chamber using a spatula as in (2).
- (4) After having sent binder, binder remained in the nozzle may drip after the pump has been stopped. Using the pump REV switch, return binder to the connection port of the liquid sending tube. Note, in this case, that the tube may come off if you return binder at a high speed of the pump.

For GB210A

- (1) If the leakage is existed between container for product and bracket at lower of the cyclone, the dried powder may be stocked onto the lower of the cyclone without falling into the container for product. Therefore, pay special attention to the unit with the container for product be mounted.
- (2) When the specimen accumulated on the nozzle tip in an ice pillar-like form, clean it off using the pulse jet switch on the touch panel.
- (3) Since the capacity of the container for product is approx. 750ml, the normal powder can fulfill almost 80% of the container by processing 200 to 250g amounts. If continuing operation more, the collecting efficiency of the powder deteriorates excessively. Stop operation for a while, and take the collected powder out of the container.
- (4) Depending on the sample to be processed, the static electricity may be occurred at cyclone. Therefore, remove the static electricity with the appropriate method. It is efficient that the wire is wounded to the glass portion for grounding, but it is more convenient to use the static electricity remover by setting against the cyclone vertically.
- (5) The cyclone may charge easily with static electricity depending on the specific specimen used, or operating environment or conditions. Implement countermeasures against static electricity such as attaching included earth clips at three positions on the clamp at the connection of the cyclone or attaching an antistatic brush to the body of the cyclone.

6. Maintenance Method

Daily Inspection and Maintenance

Warning

- Disconnect the power cable from the power source when doing an inspection or maintenance unless needed.
- Perform the daily inspection and maintenance after returning the temperature of this unit to the normal one.
- Do not disassemble this unit.

Caution

- Use a well-drained soft cloth to wipe dirt on this unit. Do not use benzene, thinner or cleanser for wiping. Do not scrub this unit. Deformation, deterioration or color change may result in.



Cleaning After Using

- (1) After completing the operation, remove the attachments following the process "Preparations " on P.12 in reverse order.
- (2) Clean the portion of attachment to which the powder is adhered.
- (3) Flow the distilled water into the sample tube by pressing the pump switch, and remove the contaminant attached to the inner of the part.
- (4) Remove the spray air tube and sample tube from the spray nozzle, and disassemble the nozzle as shown in the Photo 1. After disassembling, clean it using the supersonic cleaner. Remaining the contaminant to the inner of the part may cause the insufficient spray. Therefore, clean it completely.

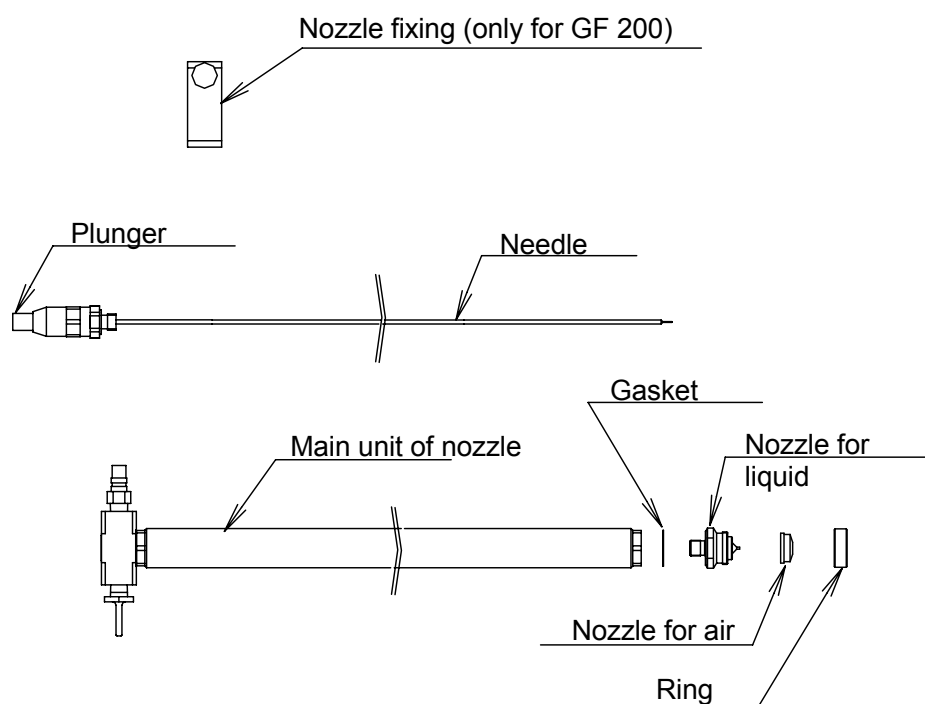

Spray nozzle exploded drawing

6. Maintenance Method

Daily Inspection and Maintenance

Filter Cleaning

- Clean up the filter in blower periodically.
 - 1) Open the door at the bottom of the front surface of the unit, and disconnect the hose from the blower.
 - 2) Open the front cover by removing the two fastening plates for the cover from the upper surface of the blower, and open the front cover, and take the filter out.
 - 3) The followings are the cleaning procedures of the filter.
 - ① Wash the filter pressing in the water repeatedly, and air-dry it.
 - ② Compressed air blowing.
 - ③ Vacuum cleaning with a cleaner.
 - ④ Press washing the filter after being immersed into the solvent that hot water (approx. 40 Celsius degree) and neutral detergent are mixed at a rate of 5:95 one whole day and night, then rinse it with water and air-dry it.
 - 4) When assembling, reversely execute the above procedure. Turn the soft surface of the filter to windward when installing the filter.

- Suction port filter

A stainless steel mesh plate is used at the suction port filter. Referring to the exploded views of the suction port on P.13 or P.15, disassemble the suction port and clean it using an electric cleaner.

Monthly maintenance

- Check the earth leakage breaker function.
 - Connect the power cord.
 - Turn the breaker on.
 - Push the red test switch by a ballpoint pen etc. If there is no problem, the earth leakage breaker will be turned off.

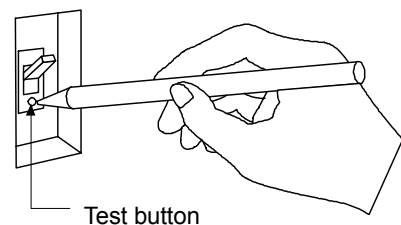

7. Long storage and disposal

When not using this unit for long term / When disposing



Caution

When not using this unit for long term...

- Turn off the earth leakage breaker and original power source for safe without fail. Also, store the glass unit after removing it from the main unit. When the glass unit is contacted to the external, it may cause the breakage.



Warning

When disposing...

- Keep out of reach of children.
- Remove the power cord.

Matters to consider when disposing of the unit

Environmental protection should be considered

- We request you to disassemble this unit as possible and recycle the reusable parts considering to the environmental protection. The feature components of this unit and materials used are listed below.

Component Name	Material
Parts of Main Unit	
Casing	Bonderizing steel plate baked with melamine resin coating, Stainless steel
Insulating material	Ceramic Felton
Specimen bed, ceiling plate, pipings	Stainless steel
Production plates	Polyethylene (PET) resin film
Tube	Silicon rubber, teflon
Electrical Parts	
Heater	Stainless steel and others
Motor	Iron, Aluminum, Copper wire and others
Circuit boards	Composites with board, condenser, resister and transformer
Power cord & wiring materials and others	Synthetic rubber, resins
Sensor	Stainless steel and others



8. When a trouble occurs

Safety unit and error indications

The table shows possible causes of activation of the safety unit and solutions.

[Error indication]

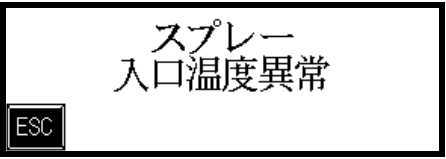
When an abnormality occurs to the inlet temperature controller or the outlet temperature controller, the touch panel at the operation panel displays the error screen. When an abnormality occurred, confirm description of the error and implement appropriate solutions.

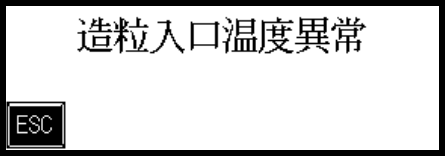
Display	Possible causes	Solutions
Inlet temperature error (GB210A) 	① Disconnection of the thermocouple sensor ② When the displayed inlet temperature is at 230°C or over ③ Malfunction of the blower	① Replacement of the thermocouple sensor ② Lower the set temperature or adjust air amount.
Outlet temperature error 	① Disconnection of the thermocouple sensor ② When the displayed outlet temperature is at 110°C or over ③ Malfunction of the blower	③ Replacement of the blower
Inlet temperature error (GB210B) 	① Disconnection of the thermocouple sensor ② When the displayed inlet temperature is at 230°C or over ③ Malfunction of the blower	③ Replacement of the blower

* When the measured temperature exceeds the set upper limit (upper limit of inlet temperature: 230°C; upper limit of outlet temperature: 110°C), "Over Heat" will appear, the heater output will stop and when that status continues for one minute, the temperature error above will be displayed. The safety unit will perform automatic REV operation for five seconds when a temperature error occurred while the blower is ON, the heater is OFF, or the liquid sending pump was in operation and then shift to the stop mode.

The same process as shown above will take place when the disconnection of the temperature sensor occurred. The temperature controller will indicate "----".

Pressing "ESC" key will release the error screen and the status will return to the "BLOWER ON" and "HEATER OFF" status.

You can display error messages in English or Chinese using the language select function.

Granule Inlet Temperature Overheat 	造粒入口温度異常 	造粒入口温度警報 
Outlet Temperature Overheat 	出口温度異常 	出口温度警報 
Spray Inlet Temperature Overheat 	スプレー 入口温度異常 	噴霧入口温度警報 

8. When a trouble occurs

Confirmation of GB210A manual and language selection display

<p>PULVIS MINI-SPRAY Model: GB210A</p> <p>HELP BLOWER</p>	<p>パルビス ミンスプレー モデル: GB210A</p> <p>HELP BLOWER</p>	<p>小型噴霧器 机型: GB210A</p> <p>HELP BLOWER</p>
<p>This Machine Used For Water Soluble Solvent</p> <p>ESC MANUAL LANGUAGE</p>	<p>本装置は 水溶性溶剤専用です</p> <p>ESC MANUAL LANGUAGE</p>	<p>此装置限于 水溶性溶剤専用</p> <p>ESC MANUAL LANGUAGE</p>
<p>Select Language</p> <p>ENGLISH 日本語 中文</p>	<p>言語切替</p> <p>ENGLISH 日本語 中文</p>	<p>选择语言</p> <p>ENGLISH 日本語 中文</p>
<p>This Machine Used For Water Soluble Solvent</p> <p>ESC MANUAL LANGUAGE</p>	<p>本装置は 水溶性溶剤専用です</p> <p>ESC MANUAL LANGUAGE</p>	<p>此装置限于 水溶性溶剤専用</p> <p>ESC MANUAL LANGUAGE</p>
<p>◇Select Inlet Control ◇Set Volume of Inlet Temperature ◇Turn BLOWER ON ◇Set Air Flow Volume</p> <p>ESC BACK NEXT</p>	<p>◇入口温度制御を選択して下さい ◇入口温度を設定して下さい ◇ブLOWERをオンして ◇風量を設定して下さい</p> <p>ESC BACK NEXT</p>	<p>◇選擇入口溫度控制 ◇設定溫度值 ◇[BLOWER] ON ◇設定風量</p> <p>ESC BACK NEXT</p>
<p>◇Turn HEATER ON ◇Wait Temperature Stabilized ◇Set Air Pressure to 0.1MPa ◇Outlet Control Changeable</p> <p>ESC BACK NEXT</p>	<p>◇ヒータをわして下さい ◇設定温度に到達後、安定を待つ ◇スプレー圧力を0.1MPaに設定 ◇出口温度制御へ切替可能</p> <p>ESC BACK NEXT</p>	<p>◇[HEATER] ON ◇等待溫度到達設定值並安定 ◇調整壓力設定為0.1MPa ◇可切換到出口溫度控制</p> <p>ESC BACK NEXT</p>
<p>◇Set Solution Tube ◇Turn PUMP FWD ON ◇Run Test Cycle by Distilled Water ◇Adjust Air flow & Pump Speed</p> <p>ESC BACK NEXT</p>	<p>◇送液チューブをセットして下さい ◇送液ポンプをわして下さい ◇蒸留水にて試運転をして下さい ◇風量と送液速度を調整して下さい</p> <p>ESC BACK NEXT</p>	<p>◇安裝送液管 ◇[PUMP FWD] ON ◇用蒸留水進行調試運行 ◇調整風量及送液速度</p> <p>ESC BACK NEXT</p>
<p>◇After Adjustment in Test Cycle ◇Set Sample Solution to Spray ◇Fine Adjust Pump Speed ◇Check Powder Collection</p> <p>ESC BACK NEXT</p>	<p>◇試運転にて調整後 ◇試料液と切替、スプレーして下さい ◇送液速度の微調整を行う ◇粉体の回収状態を確認下さい</p> <p>ESC BACK NEXT</p>	<p>◇試運行調整後 ◇使用試料溶液開始噴霧 ◇對送液速度再次微調 ◇確認粉體的回收情況</p> <p>ESC BACK NEXT</p>
<p>◇After Spray Cycle ◇Set Distilled Water to Clean ◇Set Inlet & Outlet Temperature 0°C ◇Wait Temperature Down</p> <p>ESC BACK NEXT</p>	<p>◇試料噴霧終了後 ◇蒸留水へ切替 ◇溫度設定を0°Cに下げて下さい ◇溫度下降を待つ</p> <p>ESC BACK NEXT</p>	<p>◇試料噴霧完之後 ◇換成蒸留水噴霧 ◇降低設定溫度為0°C ◇等待溫度下降</p> <p>ESC BACK NEXT</p>

8. When a trouble occurs

Confirmation of GB210A manual and language selection display

◇When Inlet Temperature < 100°C
 ◇Set Pump Speed Volume to 0
 ◇Turn PUMP FWD OFF
 ◇Shut off Pressure Air

ESC BACK NEXT

◇入口温度100°C以下になった時点で
 ◇送液ポンプのボリュームを0に絞る
 ◇送液ポンプを停止して下さい
 ◇加圧空気の圧力を0に絞って下さい

ESC BACK NEXT

◇入口温度100°C以下
 ◇送液速度調整0
 ◇[PUMP FWD]OFF
 ◇加圧空気の圧力調整0

ESC BACK NEXT

◇Turn HEATER OFF
 ◇When Inlet Temperature < 60°C
 ◇Set Flow Volume to 0
 ◇Turn BLOWER OFF

ESC BACK NEXT

◇ヒータをわして下さい
 ◇入口温度60°C以下になったら
 ◇風量ボリュームを0に絞って
 ◇ブローを停止して下さい

ESC BACK NEXT

◇[HEATER]OFF
 ◇入口温度60°C以下時
 ◇風量設定降0
 ◇[BLOWER]OFF

ESC BACK NEXT

◇Take Out Collected Powder
 ◇Turn Power Switch OFF
 ◇Shut Down Breaker
 ◇Operation End

ESC BACK NEXT

◇粉体を収集容器から取出して下さい
 ◇電源スイッチをわして下さい
 ◇ブレーカを遮断して下さい
 ◇運転終了

ESC BACK NEXT

◇从容器里取出粉体
 ◇電源開閉OFF
 ◇切断総電源
 ◇運行結束

ESC BACK NEXT

Perform a Periodic Inspection
 and Cleaning According To
 Instruction Manual

ESC BACK NEXT

取扱説明書に従い
 定期点検及び
 清掃を行って下さい

ESC BACK NEXT

請按照使用說明書
 進行定期檢查
 並清掃機器

ESC BACK NEXT

Sample Feed Rate ↑ Outlet Temp ↓
 Dried Airflow Volume ↑ Outlet Temp ↑
 Sample Concentration ↑ Outlet Temp ↑

ESC BACK NEXT

試料送液流量高：出口温度低
 乾燥空気流量高：出口温度高
 試料濃度（外部要因）高：出口温度高

ESC BACK NEXT

試料送液速度快 → 出口温度下降
 乾燥空気流量大 → 出口温度昇高
 試料濃度（外部因素）高 → 出口温度昇高

ESC BACK NEXT

PULVIS MINI-SPRAY
 Model: GB210A

HELP BLOWER

パルビス ミスプレー
 モデル：GB210A

HELP BLOWER

小型噴霧器
 机型：GB210A

HELP BLOWER

8. When a trouble occurs

Confirmation of GB210B manual and language selection display

<p>STIRRER PULVIS MINI-BED Model: GB210B</p> <p>PULSE JET HELP BLOWER</p>	<p>STIRRER ハルビス ミニベッド モデル: GB210B</p> <p>PULSE JET HELP BLOWER</p>	<p>STIRRER 小型造粒器 机型: GB210B</p> <p>PULSE JET HELP BLOWER</p>
<p>This Machine Used For Granulation & Drying</p> <p>ESC MANUAL LANGUAGE</p>	<p>本装置は造粒或は 湿粉体乾燥専用です</p> <p>ESC MANUAL LANGUAGE</p>	<p>此装置限于造粒 或湿粉体干燥专用</p> <p>ESC MANUAL LANGUAGE</p>
<p>Select Language</p> <p>ENGLISH 日本語 中文</p>	<p>言語切替</p> <p>ENGLISH 日本語 中文</p>	<p>选择语言</p> <p>ENGLISH 日本語 中文</p>
<p>This Machine Used For Granulation & Drying</p> <p>ESC MANUAL LANGUAGE</p>	<p>本装置は造粒或は 湿粉体乾燥専用です</p> <p>ESC MANUAL LANGUAGE</p>	<p>此装置限于造粒 或湿粉体干燥专用</p> <p>ESC MANUAL LANGUAGE</p>
<p>◇Set Air Intake Granulation Mounted ◇Set Drying Chamber ◇Set Primary Air Pressure to 0.3MPa ◇Set Spray Pressure to 0.01MPa</p> <p>ESC BACK NEXT</p>	<p>◇吸気管を造粒側に取り付けて下さい ◇乾燥ファンを設置して下さい ◇一次側圧力設定: 0.3MPa ◇スプレー圧力設定: 0.01MPa</p> <p>ESC BACK NEXT</p>	<p>◇将吸气管安装在造粒侧 ◇设置干燥容器 ◇调整供给空气压力: 0.3MPa ◇调整喷雾空气压力: 0.01MPa</p> <p>ESC BACK NEXT</p>
<p>◇Set Volume of Inlet Temperature (Outlet Temp is Monitor only) ◇Turn BLOWER ON, Set Volume ◇Turn HEATER ON, Wait Temp Stabilize</p> <p>ESC BACK NEXT</p>	<p>◇入口温度設定(出口温度モニタ表示のみ) ◇[BLOWER]ON, 風量を設定して下さい ◇[HEATER]ON, 温度安定を待つ ◇出口温度安定後、エージング完了</p> <p>ESC BACK NEXT</p>	<p>◇設定入口温度(出口温度只可顯示) ◇[BLOWER]ON, 設定風量 ◇[HEATER]ON, 等待温度安定 ◇出口温度安定後, 予熱結束</p> <p>ESC BACK NEXT</p>
<p>◇Turn HEATER OFF and BLOWER OFF ◇Set Sample Into Drying Chamber ◇Turn BLOWER ON, HEATER ON ◇Set Solution Tube and Binder</p> <p>ESC BACK NEXT</p>	<p>◇予備加熱後ヒータとブローをオして下さい ◇乾燥ファンに試料を入れて下さい ◇[BLOWER]ON, [HEATER]ON ◇送液チューブとバインダーをセットして下さい</p> <p>ESC BACK NEXT</p>	<p>◇予熱後[HEATER]OFF, [BLOWER]OFF ◇在乾燥容器里放置試料 ◇[BLOWER]ON, [HEATER]ON ◇設置送液管及粘台剂</p> <p>ESC BACK NEXT</p>
<p>◇Fix Pressure When Temp Stabilized ◇Turn PUMP FWD ON, Adjust Feed Rate ◇Select Feed Mode Auto/Manual ◇Set PUMP FWD to Manual Feed</p> <p>ESC BACK NEXT</p>	<p>◇出口温度安定後、圧力調整して下さい ◇[PUMP FWD]ON, 送液速度調整 ◇送液方式選択: 「自動/手動」 ◇[PUMP FWD]キーより手動運転となる</p> <p>ESC BACK NEXT</p>	<p>◇出口温度安定後, 調整圧力 ◇[PUMP FWD]ON, 調整送液速度 ◇選択送液方式「自動/手動」 ◇押[PUMP FWD]鍵進入手動運転</p> <p>ESC BACK NEXT</p>
<p>◇Select PUMP AUTO to Automatic Feed ◇Set Cycle Time For Automatic Feed ◇Set PUMP FWD for Feed Time ◇Set PUMP OFF for Wait Time</p> <p>ESC BACK NEXT</p>	<p>◇[PUMP AUTO]キーより自動運転となる ◇自動運転の場合は時間間隔を設定する ◇[PUMP FWD]噴霧時間を設定する ◇[PUMP OFF]停止間隔を設定する</p> <p>ESC BACK NEXT</p>	<p>◇押[PUMP AUTO]鍵進入自動運転 ◇選択自動運転時設定時間間隔 ◇[PUMP FWD] 設定粘台剂噴霧の時間 ◇[PUMP OFF] 設定停止時間</p> <p>ESC BACK NEXT</p>

8. When a trouble occurs

Confirmation of GB210B manual and language selection display

◇The Particle Size Get Desired
 ◇Turn PUMP FWD OFF,Binder Spray End
 ◇Turn HEATER OFF,Set Inlet Temp 0°C
 ◇Stop Pressure Air Supply

ESC BACK NEXT

◇試料が希望の粒径に到達し運転終了後
 ◇[PUMP FWD]OFFハインター噴霧終了となる
 ◇[HEATER]OFF入口温度を0°Cに設定
 ◇加圧空気の供給を停止して下さい

ESC BACK NEXT

◇要求的粒径達到之後
 ◇[PUMP FWD]OFF停止粘合劑噴霧
 ◇[HEATER]OFF,入口溫度設定為0°C
 ◇停止供給加壓空氣

ESC BACK NEXT

◇Inlet Temp<60°C,Turn BLOWER OFF
 ◇Turn LIFT DOWN Drying Chamber Down
 ◇Take Out Powder,Turn POWER OFF
 ◇Shut Down Breaker,Operation End

ESC BACK NEXT

◇入口温度<60°Cの時に[BLOWER]OFF
 ◇[LIFT DOWN]キーよりチャンパーを下げます
 ◇試料を取り出して、[POWER]OFF
 ◇ブレーカを遮断し、運転終了します

ESC BACK NEXT

◇入口温度<60°C時,[BLOWER]OFF
 ◇押[LIFT DOWN]鍵,降下乾燥容器
 ◇从容器里取出粉体,[POWER]OFF
 ◇切断総電源,運行結束

ESC BACK NEXT

Perform a Periodic Inspection
 and Cleaning According To
 Instruction Manual

ESC BACK NEXT

取扱説明書に従い
 定期点検及び
 清掃を行って下さい

ESC BACK NEXT

請按照使用說明書
 進行定期檢查
 並清掃機器

ESC BACK NEXT

Sample Feed Rate ↑ Out let Temp ↓
 Dried Airflow Volume ↑ Out let Temp ↑
 Sample Concentration ↑ Out let Temp ↑

ESC BACK NEXT

試料送液速度快→出口温度下降
 乾燥空気流量大→出口温度升高
 試料濃度(外部因素)高→出口温度升高

ESC BACK NEXT

試料送液速度快→出口温度下降
 乾燥空気流量大→出口温度升高
 試料濃度(外部因素)高→出口温度升高

ESC BACK NEXT

STIRRER PULVIS MINI-BED
 Model: GB210B

PULSE JET HELP BLOWER

STIRRER パルビス ミニベッド
 モデル: GB210B

PULSE JET HELP BLOWER

STIRRER 小型造粒器
 机型: GB210B

PULSE JET HELP BLOWER

8. In the Event of Failure...

Trouble Shooting

Symptoms	Possible causes	Countermeasures
The POWER does not turn ON.	<ul style="list-style-type: none"> ● ELB is turned OFF ● Malfunction of the power supply ● The wire ire short-circuited. ● Malfunction of power switch 	<ul style="list-style-type: none"> ● Turn the ELB ON ● Check the power supply circuit ● Replace the cord ● Replace the power switch
Blower does not activate.	<ul style="list-style-type: none"> ● Incorrect connecting of the connector of blower ● Breaking of blower input cord ● Blower switch failure ● Blower motor failure ● Blower motor brush failure ● Blower circuit failure and wiring failure 	<ul style="list-style-type: none"> ● Connect correctly. ● Replace the cart. ● Replace the touch panel, sequencer or thermo regulator. ● Replace the motor or motor substrate ● Replace the brush ● Maintain or replace the part
Heater does not activate.	<ul style="list-style-type: none"> ● Incorrect connecting of the connector of heater ● Activated the protection circuit caused by the failure of the other device (displayed error) ● Activated the protection circuit without turning on the blower switch ● Heater disconnection ● Heater switch failure ● Heater circuit failure and wiring failure 	<ul style="list-style-type: none"> ● Connect correctly. ● Solve the problem, and turn ON the switch. ● Turn ON the blower, and then turn ON the heater switch. ● Replace the part. ● Replace the touch panel or sequencer ● Maintain the part or replace the thermo regulator.
Feeding pump does not activate	<ul style="list-style-type: none"> ● The indicator of the pump adjusting dial is at "0" ● Pump switch failure ● Pump motor failure ● Pump circuit failure and wiring failure ● Imperfect nozzle attachment 	<ul style="list-style-type: none"> ● Adjust the dial. ● Replace the touch panel or sequencer ● Replace the motor or driver ● Maintain the part ● Check and adjustment of attachment status of the nozzle
Pulse jet does not activate	<ul style="list-style-type: none"> ● Failure of pressuring air source ● Connecting failure of tube ● Solenoid valve failure ● Pulse jet switch failure ● Pulse jet circuit failure and wiring failure 	<ul style="list-style-type: none"> ● Make arrangement aiming for appropriate status. ● Maintain or replace the part. ● Replace the part. ● Replace the touch panel or sequencer ● Maintain the part

8. In the Event of Failure...

Trouble Shooting

Problem	Possible Cause	Solution
Thermo regulator failure	<ul style="list-style-type: none"> ● Defective display function ● Sensor failure ● Activated overheating protection function 	<ul style="list-style-type: none"> ● Maintain or replace the part. ● Replace the part. ● Lower the temperature setting
Adjusting dial (Not activated blower and pump)	<ul style="list-style-type: none"> ● Adjusting circuit failure and wiring failure ● Lack of capacity of heater due to excessive drying airflow 	<ul style="list-style-type: none"> ● Maintain the part or replace the thermo regulator. ● No error. For operating this unit with high temperature, decrease the flow rate of the drying air or increase the setting value.
Display lamp (The lamp will not switch even if the suction port connection is switched.)	<ul style="list-style-type: none"> ● Limit switch failure ● Limit switch imperfect adjustment ● Imperfect circuit and wiring 	<ul style="list-style-type: none"> ● Replace the limit switch. ● Adjust so that the limit switch touches the suction filter case. ● Repair the defective point.
Lift switch (Pressing the lift switch will not move the stage)	<ul style="list-style-type: none"> ● Lift switch failure ● Imperfect circuit and wiring ● Motor failure 	<ul style="list-style-type: none"> ● Replace the lift switch. ● Repair the defective point. ● Replace the motor.
Stirrer switch (Stirrer blade do not operate.)	<ul style="list-style-type: none"> ● Clogging of the stage rotation part with powder. ● Imperfect circuit and wiring ● Motor failure 	<ul style="list-style-type: none"> ● Remove power and other dusts. ● Repair the defective point. ● Replace the motor.

- ◆ In the case if the error other than listed above occurred, turn off the power switch and primary power source immediately. Contact the shop of your purchase or nearest Yamato Scientific Service Office.

9. After Service and Warranty

When requesting a repair

When requesting a repair

If any trouble occurs, immediately stop operation, turn the power switch off, pull out the power plug and contact your dealer, our sales office or our customer service center.

Information necessary for requesting a repair

- Model name of the product
 - Serial number
 - Date (y/m/d) of purchase
 - Description of trouble (as in detail as possible)
- } See the warranty card or the nameplate on the unit.
} See the section “3.Names of parts and their function” on page 9.

Be sure to indicate the warranty card to our service representative.

Warranty card (attached separately)

- Warranty card is given by your dealer or one of our sales offices and please fill in your dealer, date of purchase and other information and send it to our customer service center by Facsimile (03-3231-6523). Then, store it securely.
- Warranty period is one full year from the date of purchase. Repair service for free is available according to the conditions written on the warranty card.
- For repairs after the warranty period consult your dealer, one of our sales offices or our customer service center.
Paid repair service is available on your request when the product's functionality can be maintained by repair.

Minimum holding period of repair parts

The minimum holding period of repair parts for this product is seven years after end of production. Repair parts here refer to parts necessary for maintaining performance of the product.

10. Specification

Specifications of main unit

GB210A	Configuration	Basic unit [GB210] + Mini Splay Attachment [GF-300]			
	Function	Splay drying			
	Sample for drying	Solution, Suspension, Emulsion (Flammable organic solvent is invalid.)			
	Total weight	Approx. 121kg			
GB210B	Configuration	Basic unit [GB210] + mini bed attachment[GF200]			
	Function	Granulation and drying in the flow layer			
	Total weight	Approx. 123kg			
Basic unit [GB210]	Thermo regulator	PID digital thermo regulator			
	Heater	2kW~2.88kW			
	Blower	Brushless motor			
	Stirring mechanism	Induction motor (Only for GB210B)			
	Sample feeding pump	Proportioning Peli pump			
	Pressure gauge for spray air	Pressure gauge for bourdon tube Measurement range: 0 to 294kPa			
	Blowout mechanism for pressurizing air	Use pulse jet type solenoid valve			
	Temperature adjustment range	INLET:0~220°C/ OUTLET : 0~60°C			
	Temperature adjustment accuracy	±1°C			
	Temperature display	Digital display of the temperature around Inlet/Outlet (metal-sheathed thermocouple element K)			
	Adjusting range for drying air	0~0.7m ³ /min			
	Power supply * ¹	AC200V single phase 16A (AC220V 17A AC240V 18A)			
	External dimensions * ²) (W×D×H)	760×420×1350			
	Weight	Approx. 110kg			
	Attached accessories	Specimen tube	Silicon	I.D.2 mm×O.D.4 mm×1m	2
			Tiron	I.D.2 mm×O.D.4 mm×1m	3
Outlet temperature sensor				1	
Exhaust hose		Made of vinyl chloride	I.D.:50 mm×2m	1	
Hose band		#64		1	
Container pedestal		(Only for GB210A)		1	
Sample box				1	
Knurled screw				4	
Tetlon braded hose		5m		1	
Hose clamp				2	
Earth wire				1	
Warranty card				1	
Operation manual				1	

※GB210A is for water soluble solvent only. Be sure to connect it to the separate optional GAS410 when you are going to use an organic solvent. Also note that GAS410 cannot be connected to GB210B.

10. Specification

Mini bed attachment [GF200]	Model	GF200		
	Processing capacity	50~300g		
	Spray nozzle	Dual fluid nozzle 1A		
	Flow layer chamber capacity	3L		
	Glass parts	Made of ultra hard glass		
	Stirrer blades	Integrated in the flow layer chamber (Stirring mechanism of GB210 is used)		
	Filter	Polyester (Carbon fiber blended membrane laminated PTFE)		
	Cleaning of filter	Pulse jet system (Pressurized air blower mechanism of GB210 is used)		
	Weight	Approx. 13 kg		
	Parts list	Flow layer chamber		1set
		Interim pipe (O ring on P16 and P135 included)		1set
		Butterfly nut M6		3
		Flat washer M6		6
		Hex bolt M6×30		3
		Spring washer M6		3
		Cap :silicon		1
Hose : ϕ 38.1× ϕ 41.7×800L silicon			1	
Hose clip			2	
O ring P145			1	
Pipe			1	
Filter (O ring P30 included)			1set	
Filter chamber			1	
Flange			1	
Packing C t5mm Silicon			1	
Spray nozzle		1set		
Filter retainer nut		1		
Polyvinyl alcohol 5% solution 50g	Polyethylene tank		1	
Sintered alumina 300g	polyethylene tank		1	
Round single-ended wrench			1	
Warranty card			1	

10. Specification

Mini Splay Attachment [GF300]	Model	GF300		
	Amount of water evaporation	Max. Approx. 1300ml/h		
	Spray nozzle	Binary Nozzle 1A		
	Drying chamber	Made from super hard glass		
	Cyclone	Made from super hard glass		
	Container for product	Made from super hard glass		
	Dust removal of nozzle tip	Pulse jet type (used the pressuring air blower mechanism for GB210 model)		
	Weight	Approx. 11 kg		
	Parts list	Cyclone		1set
		Drying chamber		1set
		Product collecting container		1
		Container holding band		1
		Packing 40A, 50A		1each
		Power clamp 40A, 50A		1each
		Cap		1
		Connecting ferrule (D)		1
		PFA wave shaped tube 1-1/2, 3 feet long (for connecting the cyclone)		1
Hose clip			2	
Distributor (O-rings P16, P135 included)			1	
Hex bolt M6 x 20			3	
Flat washer M6			3	
Spring washer M6			3	
Aluminum honeycomb			1	
Pipe			1	
Spray nozzle		1		
Round single-ended wrench		1		
Polyethylene tank for 100g of 5% sodium chloride solution		1		
Warranty card		1		

*1 Including capacity of service receptacle (2A).

*2 The outer dimension does not include the projection part.

Please remind that this product may be changed the specification and others for revision without any announce to the user.

11. Wiring Diagram

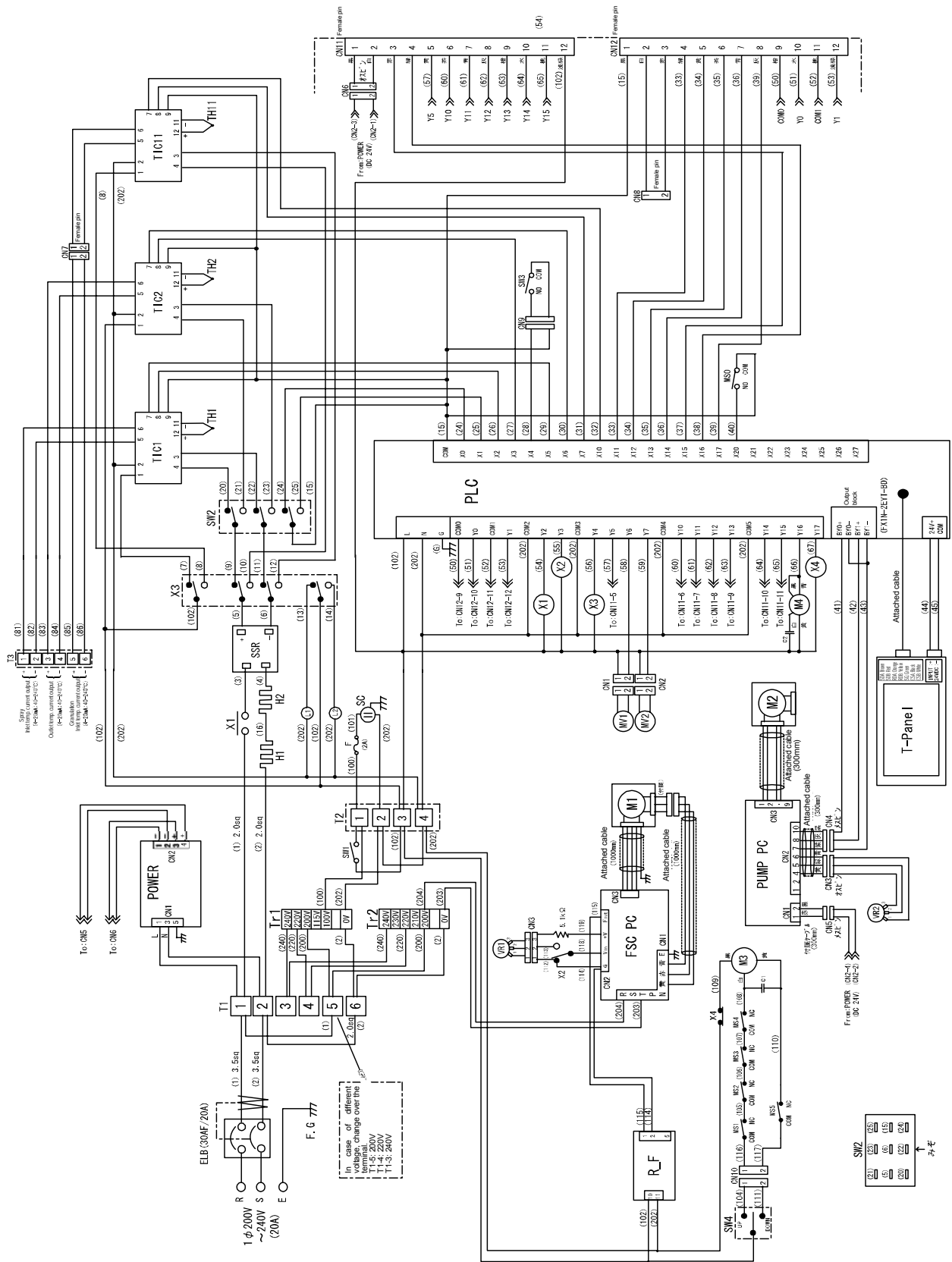

12. System Chart

System Chart of GB210B

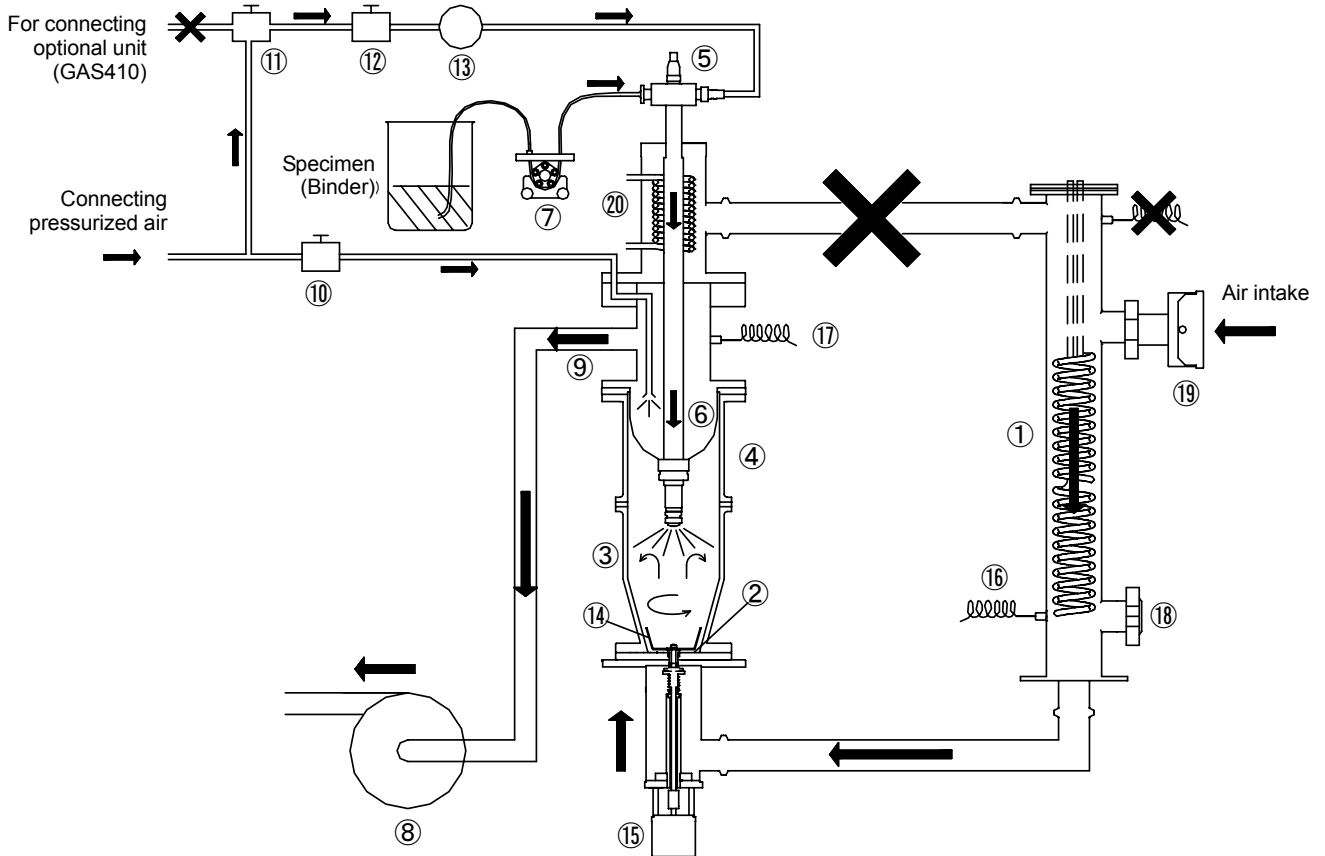

No	Part name	No	Part name
①	Heater	⑪	3-way solenoid valve
②	Micro pore plate	⑫	Needle valve
③	Flow layer chamber	⑬	Pressure meter
④	Filter chamber	⑭	Stirring blade
⑤	Nozzle	⑮	Stirring motor
⑥	Filter	⑯	Inlet temperature sensor
⑦	Liquid sending pump	⑰	Outlet temperature sensor
⑧	Blower	⑱	Blind
⑨	Interim pipe	⑲	Suction port, suction filter
⑩	Solenoid valve	⑳	Nozzle cooling connection port

12. System Chart

System Chart of GB210A

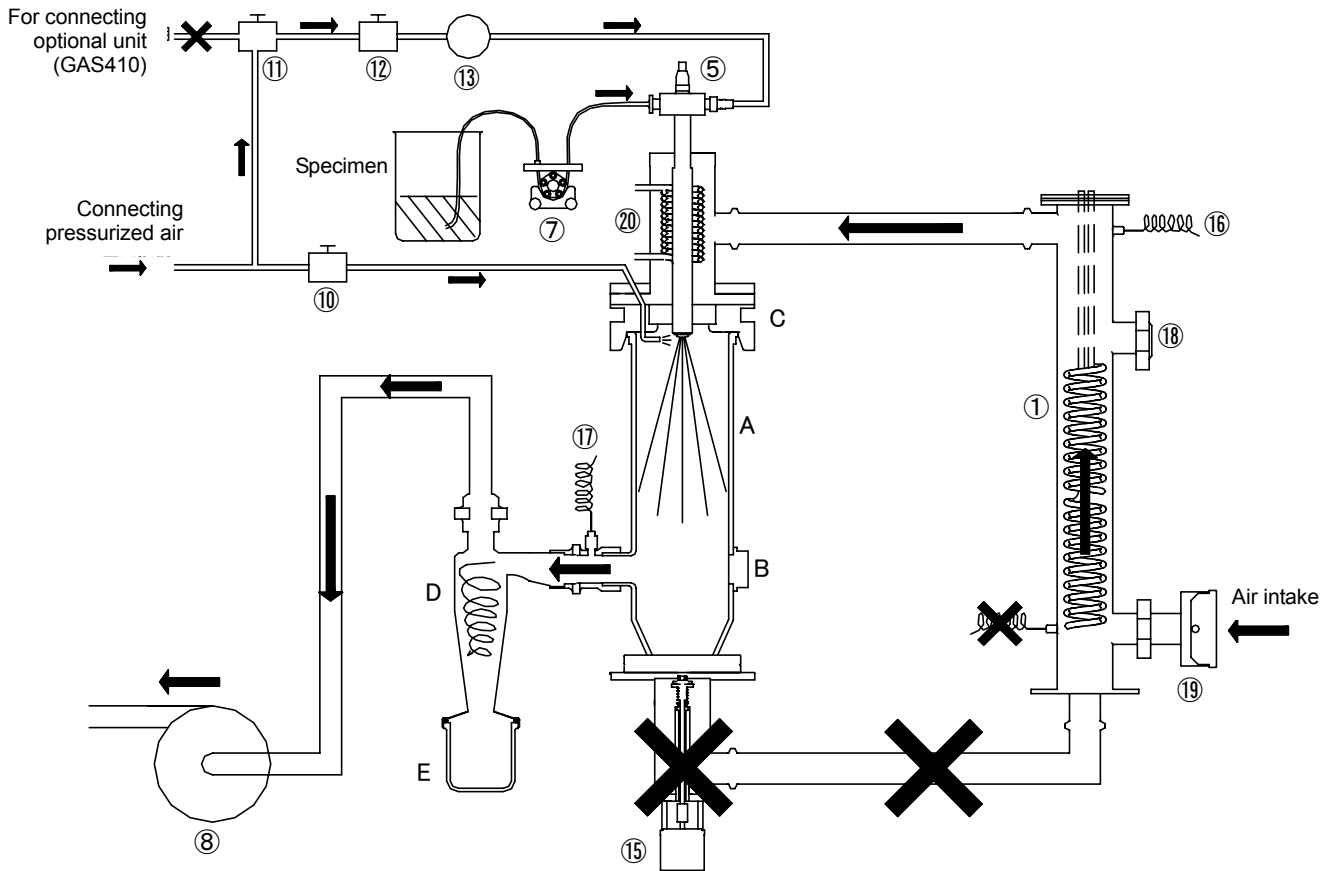

No	Part name	No	Part name
①	Heater	⑰	Inlet temperature sensor
⑤	Spray nozzle	⑱	Blind
⑦	Liquid sending pump	⑲	Suction port, suction filter
⑧	Blower	⑳	Nozzle cooling connection port
⑩	Solenoid valve	A	Drying chamber
⑪	3-way solenoid valve	B	Cap
⑫	Needle valve	C	Distributor
⑬	Pressure meter	D	Cyclone
⑮	Stirring motor (Not used)	E	Product collecting container
⑯	Inlet temperature sensor		

13. Principle of Operation

Principle of Operation

Refer to " System Chart" on P.37.

The sample is fed from the appropriate container to ⑤ spray nozzle with ⑦ feeding pump. Moreover, the compressed air pressure from the compressor is regulated by ⑫ needle valve, and sent to ② spray nozzle. At the tip of the nozzle, the compressed air mixed with the sample, and the mixed sample is sprayed inside 'A' drying chamber. This sample becomes drop shape that the particle diameter is approx. 20 μ and the surface area is 3,000 cm² per 1 liter of sample.

On the other side, air is suctioned into the unit by ⑧ blower, and heated up till the temperature set on ① heater. Since the contact area of the heated air and the sample is very large, the approx. 90% or more of the moisture will be evaporated in the dry chamber momentarily.

The sample that became fine powder by drying is fed to 'D' cyclone under further drying, and separated from the evaporated part here, and then, fed to 'E' container for product. Time after the sample is sprayed with the nozzle till it is fed into this container does not take 0.5 seconds. Moreover, since the sample powder is always surrounded with the solvent vapor (moisture vapor), the temperature does not rise extremely around the particle due to the vaporization heat. Therefore, in case of the heat-sensitive material such as an enzyme, disintegration can be executed without dropping degree of activity even under the condition as a temperature around outlet= 80 Celsius degree.

The evaporated moisture is evacuated to outside via the blower.

The temperature conditions under examination are displayed on the display panel by the inlet temperature sensor and the outlet temperature sensor. Moreover, the airflow that dries the sample is measured by the wind velocity sensor in the wind-flow tube, and is displayed on the display panel.

In case that the sample adhesion to the nozzle tip is outstanding, open ⑩ solenoid valve to let the pressurizing air blow to the nozzle tip from 'C' distributor in order to remove the adhesives. If necessary, remove 'B' cap to take the outside air into the inside of the chamber.

14. Replacement parts table

Replacement parts for GB210

Part name	Standards	Manufacturer	Code No.
Reversible motor	4RK25GN-A For stage	Oriental Motor	2140056006
Linear head	4LB10N-1 For stage	Oriental Motor	2140056007
Micro switch	V-104-1A4	Omron	2020020001
Slide rail	C115-1148A	Accuride Japan	4300016001
Motor	21K6A-A For stirring	Oriental Motor	2140056005
※ O ring	P18 4-types D Viton String part	Yamato Scientific	4210026022
※ O ring	P110 4-types D Viton for stage	Yamato Scientific	4210026040
※ O ring	P23 4-types D Viton For upper cylindrical pipe	Yamato Scientific	4210026024
※ O ring	P145 4-types D Viton For upper cylindrical pipe	Yamato Scientific	4210026045
Ball bearing	R-1560X2ZZ String part	NMB	4180126007
Thrust ball bearing	SST-1260 String part	NMB	4180126002
Brush less motor	BBW1006BL2E	Matsushita	LT00029635
Driver	SPA1006BL4E	Matsushita	LT00029636
※ Packing (C)	AD311S_40910 Neoprene	Yamato Scientific	LT00027737
※ Packing (D)	AD311S_40900 Neoprene	Yamato Scientific	LT00027734
※ Packing (E)	AD311S_40990 Neoprene	Yamato Scientific	LT00027740
※ Filter	AD311S_40540 PET	Yamato Scientific	LT00027739
※ Heat resistant hose	GS type 38 × 42 × L600	Tigers Polymer	LT00029643
Heat resistant flexible hose	MD25 φ50 × 380L	Totaku	3040186013
Pressure meter	DU-1/4-60-3K	Nisshin Gauge	5050036002
Needle valve	2412T-S-1/8-7	Kojima	3150116002
Toggle switch	2M-2032	Nikkai	LT00027715
Power switch	HLS112A-G	Fujisoku	2010086022
Volume	RV24YN20S B103 077C	Cosmos	LT00027710
Stage locker switch	MLW-3028	Nikkai	LT00029641
Lever	AT-426W	Nikkai	LT00029642
Flow meter	A5110-15	Asahi Keiki	LT00004429
※ Neon lamp	BN9E-G	Satoh Parts	2090060041
Temperature sensor (outlet)	08B-0145-Y	Yamato Scientific	LT00026545
Temperature sensor (outlet) harness	08B-0181-Y	Yamato Scientific	LT00026546
Temperature sensor (inlet)	08B-0142-Y	Yamato Scientific	LT00026543
Temperature sensor (below inlet)	08B-0143-Y	Yamato Scientific	LT00026544

14. Replacement parts table

Part name	Standards	Manufacturer	Code No.
Interface cable (with a connector)	RNJC-RM-20-12-A-1(CN12)	Misumi	LT00027660
Interface cable (with a connector)	RNJC-RF-20-12-A-1(CN11)	Misumi	LT00027659
Bellows	MFK040-L130 For connecting upper cylindrical pipe	Mirapro	LT00027775
Clamp	MCK-1040	Mirapro	P57
※ Center ring	MCK-2040	Mirapro	LT00027798
Blank flange	MCK-4040	Mirapro	LT00027775
※ Seize heater	AD311S_30020	Yamato Scientific	LT00027773
Solenoid valve	VX2230K-02-1G1	SMC	LT00027695
Solenoid valve	VX3334K-02-1GR1-B Three-way valve	SMC	LT00031493
Motor	FY8PF15N-D3 For sending liquid	Nihon Servo	LT00027675
Driver	FYD815SD3 For sending liquid	Nihon Servo	LT00027693
Gear head	8H30FBN-100 For sending liquid	Nihon Servo	LT00027684
Bearing	SSR-1030ZZ For sending liquid	NMB	4180126001
※ Teflon flexible tube	$\phi 6.35 \times \phi 4.35 \times 200$	Yamato Scientific	3040000015
Micro switch	SS-01GL2 Nozzle por	Omron	A0020084
Teflon tube	$\phi 8 \times \phi 6 \times L1000$	Yamato Scientific	3040146003
PLC connection cable	GT10-C10-R4-8P	Mitsubishi	LT00027716
Touch panel	GT1030-HBDW 4.5 inches	Mitsubishi	LT00035099
PLC IN24/OUT16	FX1N-40MR	Mitsubishi	LT00028131
Output block	FX1N-2EYT-BD	Mitsubishi	LT00027717
Temperature controller	TTM204-Q-PI-RSV	Toho Denshi	LT00027709
ELB	BJS203100S1	Matsushita	2060050011
SSR	TRS1225	Toho Denshi	LT00029541
Relay	LY1N AC100V For heater blower	Omron	LT00027662
Relay	MY4N AC100V	Omron	2050130003
Socket	PTF08A	Omron	LT00017832
Socket	PYF14A	Omron	LT00017913
Transformer	AD21-500AZ	TOYOZUMI	W0124
Transformer	UD22-02KB2	TOYOZUMI	LT00029638
Switching power supply	LEA50F-24	COSEL	LT00027661
※ Liquid sending tube	$\phi 2 \times 4 \times L1000$ Silicon	Yamato Scientific	LT00027796
※ Liquid sending tube	$\phi 2 \times 4 \times L1000$ Tiron	Yamato Scientific	LT00028790

Note: Parts marked with * are consumable parts.

14. Replacement parts table

Replacement parts for CF200

	Part name	Standards	Manufacturer	Code No.
	Spray nozzle set	GF200-30000	Yamato Scientific	LT00028787
※	O ring	P135 4 types D Viton	Yamato Scientific	4210026044
※	O ring	P16 4 types D Viton	Yamato Scientific	4210026021
※	O ring	P30 4 types D Viton	Yamato Scientific	4210026026
※	O ring	P145 4 types D Viton	Yamato Scientific	4210026045
※	Packing C	GF200_40310 silicon	Yamato Scientific	LT00028762
	Filter chamber	GF200_30120 ultra hard glass	Yamato Scientific	LT00028126
	Thrust ball bearing	SST-1260	NMB	4180126002
	Packing (A)	GF300_40160 Silicon	Yamato Scientific	LT00024524
	Packing (B)	GF300_40150 Silicon	Yamato Scientific	LT00024523
	Micro pore plate	GF200_40160 SUS304	Yamato Scientific	LT00028128
	Cap	GF300_40100 Silicon	Yamato Scientific	LT00027544
	Flow layer chamber	GF200_30070 Ultra hard glass	Yamato Scientific	LT00028129
	Clean out needle additional machining diagram	GF200-40000 14293-6-1/16-SS Secondary machining	SSJ	LT00028432
※	Packing	CP-4042-2-TEF	SSJ	3280016002
※	Gasket (A)	CP104369-TEF	SSJ	3280016003
※	Gasket (B)	CP3612-TEF	SSJ	3280016006
※	O ring	JASO-1017 Haika		4210076002
	Filter	GF200-30100 polyester	Yamato Scientific	LT00028130
	Filter packing	GF200_40260 silicon	Yamato Scientific	LT00028458
	Hose	SRDH(GS type)L800mm	Tigers Polymer	3040080004
	Hose clip	JCS-Win-2A φ35~50	Okada Sangyo	LT00027550

Note: Parts marked with * are consumable parts.

14. Replacement parts table

Replacement parts for GF300

Part name	Standards	Manufacturer	Code No.
Drying chamber 1 set	GF300-30000 Ultra hard glass	Yamato Scientific	LT00028136
Cyclone 1 set	GF300-30060 Ultra hard glass	Yamato Scientific	LT00028785
Container retaining band	GF300-40000 stainless steel	Yamato Scientific	LT00027540
Spray nozzle 1set	GF300-30100	Yamato Scientific	LT00028786
※ O ring	P16 4 types D Viton	Yamato Scientific	4210026021
※ Aluminum honeycomb	GF300-40120	Yamato Scientific	LT00027548
※ O ring	P135 4 types D Viton	Yamato Scientific	F0020073
※ Cap	GF300-40100 silicon	Yamato Scientific	LT00027544
Connection ferrule (D)	GF300-40080	Yamato Scientific	LT00027543
※ PFA corrugated tube	1·1/2 3feet (915mm)	lida rubber	LT00027545
Hose clip	JCS-Win-2A φ 35~50	lida rubber	LT00027550
※ Packing	40A silicon	OSAME	F0220141
※ Packing	50A silicon	OSAME	F0220143
Power clamp	40A	OSAME	R0100009
Power clamp	50A	OSAME	R0100012
Product collecting container	GF300-30090	Yamato Scientific	LT00027539
Clean out needle additional machining diagram	GF300-40190 14293-6-1/16-SS Secondary machining	SSJ	LT00027552
※ Packing	CP-4042-2-TEF	SSJ	3280016002
※ Gasket (A)	CP104369-TEF	SSJ	3280016003
※ Gasket (B)	CP3612-TEF	SSJ	3280016006
※ O ring	JASO-1017 Haika		4210076002

Note: Parts marked with * are consumable parts.

15. List of Dangerous Substances



Never use explosive substances, flammable substances and substances that include explosive or flammable ingredients in this unit. Otherwise explosion or fire may result

ADL311S supports organic solvents by connecting it to the optional GAS410. Carefully read the operation manual of GAS410 and take special care for handling of organic solvents.

Explosive substance	Explosive substance	①Nitroglycol, glycerine trinitrate, cellulose nitrate and other explosive nitrate esters
		②Trinitrobenzen, trinitrotoluene, picric acid and other explosive nitro compounds
		③Acetyl hydroperoxide, methyl ethyl ketone peroxide, benzoyl peroxide and other organic peroxides
Flammable substances	Explosive substances	Metal "lithium", metal "potassium", metal "natrium", yellow phosphorus, phosphorus sulfide, red phosphorus, celluloids, calcium carbide (a.k.a, carbide), lime phosphide, magnesium powder, aluminum powder, metal powder other than magnesium and aluminum powder, sodium dithionous acid (a.k.a., hydrosulphite)
	Oxidizing substances	①Potassium chlorate, sodium chlorate, ammonium chlorate, and other chlorates
		②Potassium perchlorate, sodium perchlorate, ammonium perchlorate, and other perchlorates
		③Potassium peroxide, sodium peroxide, barium peroxide, and other inorganic peroxides
		④Potassium nitrate, sodium nitrate, ammonium nitrate, and other nitrates
		⑤Sodium chlorite and other chlorites
		⑥Calcium hypochlorite and other hypochlorites
	Flammable substances	①Ethyl ether, gasoline, acetaldehyde, propylene chloride, carbon disulfide, and other substances with ignition point at a degree 30 or more degrees below zero.
		②n-hexane, ethylene oxide, acetone, benzene, methyl ethyl ketone and other substances with ignition point between 30 degrees below zero and less than zero.
		③Methanol, ethanol, xylene, pentyl acetate, (a.k.a.amyl acetate) and other substances with ignition point between zero and less than 30 degrees.
		④Kerosene, light oil, terebinth oil, isopenthyl alcohol(a.k.a. isoamyl alcohol), acetic acid and other substances with ignition point between 30 degrees and less than 65 degrees.
Combustible gas	Hydrogen, acetylene, ethylene, methane, ethane, propane, butane and other gases combustible at 15°C at one air pressure.	

(Quoted from the separate table 1 in Article 6, the enforcement order of the Industrial Safety and Health Law)

Limited liability

Be sure to use the unit strictly following the handling and operating instructions in this operating instruction.

Yamato Scientific Co., Ltd. assumes no responsibility for an accident or a malfunction caused by use of this product in any way not specified in this operating instruction.

Never attempt to perform matters prohibited in this operation instruction.

Otherwise, an unexpected accident may result.

Notice

- **Descriptions in this operating instruction are subject to change without notice.**
- **We will replace a manual with a missing page or paging disorder.**

Instruction Manual

PULVIS MINI SPRAY /PULVIS MINI BED

GB210A/GB210B

Revised Feb. 27, 2012

Yamato Scientific Co., Ltd.

〒103-8432

2-1-6, Nihonbashi, Honcho, Chuo-ku,
Tokyo

Customer support center



Tool free: 0120-405525

<http://www.yamato-net.co.jp>